

YANMAR DIESEL ENGINE

PARTS CATALOG

● パーツカタログ

000Y00R4520



MODEL

3TNE74-SA, G2A

How to read this Parts Catalog.

- Parts mentioned in this Parts Catalog may not necessarily be standard equipping parts.
- Parts change may be made without prior notice.
- Form of this Parts Catalog.

① REF.	② LEV.	③ PART NO.	DESCRIPTION	④ QTY	⑤ I	⑥ P	⑦ U	⑧ A	⑨ R
1		729595-51390	FUEL INJECTION PUMP (W/BOOST)	1	1	1	1	1	
1-1		29595-51391	FUEL INJECTION PUMP	1	1	1	1	1	N
3		26022-060162	SCREW M 6X 16	9	9	9	9	9	
3-1		26022-060162	SCREW M 6X 16	4	4	4	4	4	K
4		129470-51040	CAMSHAFT	1	1	1	1	1	
5		122710-51050	BEARING, ROLLER	2	2	2	2	2	
6		129470-51050	RETAINER	1	1	1	1	1	
7			OIL	1	1	1	1	1	

REMARKS (⑥)
 1) FUEL INJECTION PUMP (W/BOOST) TYPE, OPTIONAL PART, TO E/00155, (4JH-DT, 4JH-DTZ)

① Ref. No.

The Ref. No. in the list may not be accord with the Ref. No. on illustration.

(Ex.) Illustration No. List head No.

1 1 (Before change) → 1-1 (After change)

When interchangeable symbol N, R and K, illustrations for the new parts are sometimes omitted.

② Lev.(Level)

Indication and Meaning of Level

Level: Hereunder is given the relation among the number of dots (·), the level and the nominal parent-child relationship.

-Parent parts (Assembly parts)
-Child parts included in "•" (Semi-Assembly parts, component parts of Assembly parts.)
-Child parts included in "••", Grand-child parts in terms of "•", (Component parts of Semi-Assembly parts.)

Note) A part of non-sale parts are illustrated but not listed.

③ Change Mark

Change Mark "1" is given to the part for which a design change was made at this time. The design change was not shown in the last published Parts Catalog.

④ Interchangeability Mark

In the case where a part change took place, one of the following interchangeability marks is indicated for that part.

Symbol	Interchangeability	Contents note
N	Old ⇄ NEW	New Part is interchangeable for Old Part but not interchangeable conversely.
Q	Old ⇄ NEW	New Part is not interchangeable for Old Part but interchangeable conversely.
R	Old ⇄ NEW	New Part is interchangeable for Old Part and vice versa.
S	Old ⇄ NEW	New Part is not interchangeable for Old Part and vice versa.
W		Part newly added.
Z		Part discontinued.
F		Not interchangeable single part but interchangeable by set of the related parts.
K		Changed only in quantity used.

⑤ Effective Machine No.

When a part is changed, Effective Machine No. of a Model for which the part is applicable is indicated in each column of (A) - (F).

Product symbol	Product No.	Product symbol	Product No.
C	Clutch No., Copressor No.	M	Machine No.
D	Drive No.	T	Tractor No.
E	Engine No.	Note 1)	Date

Note 1) Date may follow the symbol in some cases. (Ex.) ※1990. 02

Note 2) As far as engine models shown by "XXX" are concerned, the modification of the parts could not be predicted or the engine models themselves could not be identified.

Note 3) (A = E00185) means that the design change on the part has been effective for the model at the column (A) (in this case, for 4JH-DT) on and from E (Engine Serial Number) 00185.

⑥ Remarks Mark

Figures or alphabets (Symbols) are entered in the remark column.

The comments (remarks) on the pertinent parts are indicated in the lower part of the list by the same symbols as those stated above.

520)

+-----+
| 1B01 |
+-----+

*
* (001) ENGINE 3TNE74-SA, G2A *
*

GROUP NO.	GROUP NAME	LOCATION NO.
1	CYLINDER BLOCK	1B02
2	GEAR HOUSING	1B03
3	FLYWHEEL HOUSING & OIL SUMP	1B04
4	CYLINDER HEAD & BONNET	1B05
5	SUCTION MANIFOLD & AIR CLEANER	1B07
6	EXHAUST MANIFOLD & SILENCER	1B08
7	CAMSHAFT & DRIVING GEAR	1B09
8	CRANKSHAFT & PISTON	1B10
9	LUB.OIL SYSTEM	1B11
10	COOLING WATER SYSTEM	1B12
11	RADIATOR	1B13
12	FUEL INJECTION PUMP	1B14
13	GOVERNOR	1B15
14	FUEL INJECTION VALVE	1C01
15	FUEL FILTER	1C02
16	ENGINE CONTROL DEVICE	1C03
17	STARTING MOTOR	1C04
18	GENERATOR	1C05
19	PANEL	1C06
20	GASKET SET	1C07

1. CYLINDER BLOCK

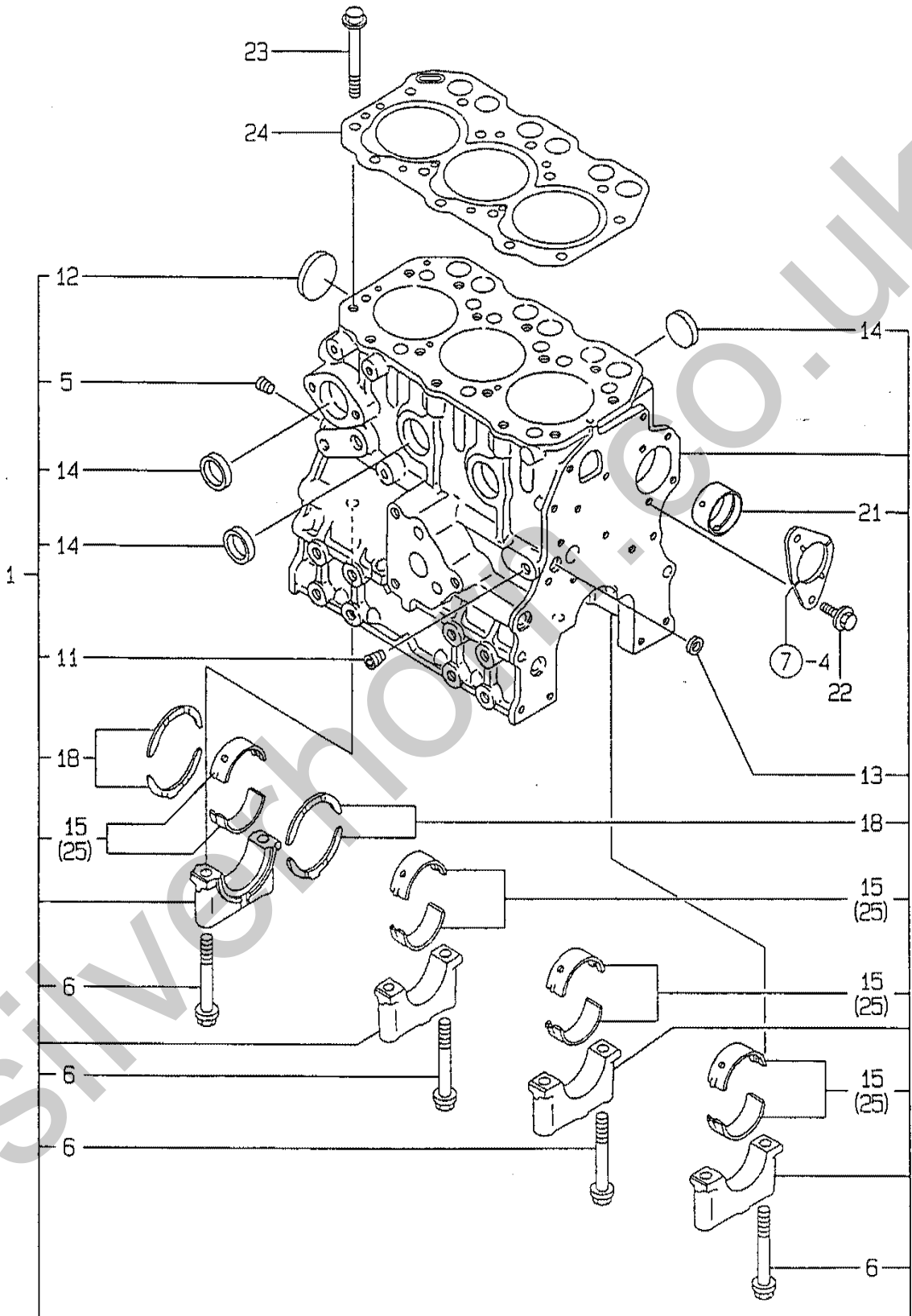

+-----+
 I 1B02 I
 I(1B01)I
 +-----+
 Y00R4520

(1) CYLINDER BLOCK

(A)=3TNE74-SA (D)=
 (B)=3TNE74-G2A (E)=
 (C)= (F)=

REF. NO.	LEV. 0	PART NO.	DESCRIPTION	-----Q'TY-----						I P/U A R
				(A)	(B)	(C)	(D)	(E)	(F)	
1	.	719623-01560	BLOCK ASSY, CYLINDER	1	1					
5	..	119600-01050	PLUG PT1/4	1	1					
6	..	119620-02020	BOLT	8	8					
11	..	23871-010000	PLUG PT1/8, SCREW	1	1					
12	..	27231-450000	PLUG 45	1	1					
13	..	27241-120000	PLUG 12	1	1					
14	..	27241-300000	PLUG 30	6	6					
15	..	719620-02800	MAIN BEARING	4	4					
18	..	719620-02930	BEARING, THRUST	2	2					
21	..	119620-02410	BUSH, CAMSHAFT	1	1					
22	.	26106-060122	BOLT M 6X 12 PLATED	2	2					
23	.	119620-01200	BOLT, CYLINDER HEAD	14	14					
24	.	119623-01330	GASKET, CYL. HEAD	1	1					(G)
25	.	719620-02870	MAIN BEARING US=0.25	4	4					(1)

----- REMARKS -----

I(1)UNDER-SIZE(U.S=0.25)PART.
 I(G)THESE PARTS ARE SOLD BY FIG.20,
 I REF.NO.1,2.

+-----+
 I 1B03 I
 I(1B01)I
 +-----+
 Y00R4520

(2) GEAR HOUSING

(A)=3TNE74-SA (D)=
 (B)=3TNE74-G2A (E)=
 (C)= (F)=

REF. NO.	LEV. 0	PART NO.	DESCRIPTION	-----Q'TY-----						I P/U A R
				(A)	(B)	(C)	(D)	(E)	(F)	
1	.	119610-01590	COVER ASSY, HOUSING	1	1					
4	..	119620-01800	SEAL HTC456208, OIL	1	1					
5	.	119660-01911	PIPE, KNOCK	4	4					
6	.	24311-000120	O-RING 1A P 12.0	2	2					(G)
7	.	26106-060162	BOLT M 6X 16 PLATED	7	7					
8	.	26106-060302	BOLT M 6X 30 PLATED	8	8					
9	.	26106-060602	BOLT M 6X 60 PLATED	1	1					
10	.	26106-060602	BOLT M 6X 60 PLATED	3	3					
11	.	26106-060802	BOLT M 6X 80 PLATED	6	6					
12	.	124160-01751	CAP, LUB.OIL SUPPLY	1	1					
13	.	24311-000320	O-RING 1A P-32.0	1	1					(G)
14	.	119610-01490	HOUSING ASSY, GEAR	1	1					
17	..	119660-01510	PLUG 10X14	1	1					
18	..	121450-01560	STUD M 8X 22	4	4					
19	..	22351-040010	SPRING PIN 4X10	2	2					
20	.	119660-01551	COVER	1	1					
21	.	119660-01562	GASKET, (NON-ASB.)	1	1					(G)
22	.	119660-01570	STUD M6X12	4	4					
23	.	119623-01950	SHIM PACK	1	1					
30	.	194990-22050	NUT W/WASHER 8	4	4					
31	.	26366-060002	NUT M 6	4	4					
32	.	121023-01550	COVER, BLIND	1	1					
33	.	24341-000240	O-RING 1A S-24.0	1	1					(G)
34	.	26106-060182	BOLT M 6X 18 PLATED	2	2					
35	.	129150-91400	GEAR UNIT, TACHOMETER	1	1					(1)
37	..	24341-000240	O-RING 1A S-24.0	1	1					(1)
38	.	26106-060162	BOLT M 6X 16 PLATED	2	2					(1)

----- REMARKS -----

(G) THESE PARTS ARE SOLD BY FIG.20,
 I REF.NO.1,2.
 I(1) FOR PANEL

3. FLYWHEEL HOUSING & OIL SUMP

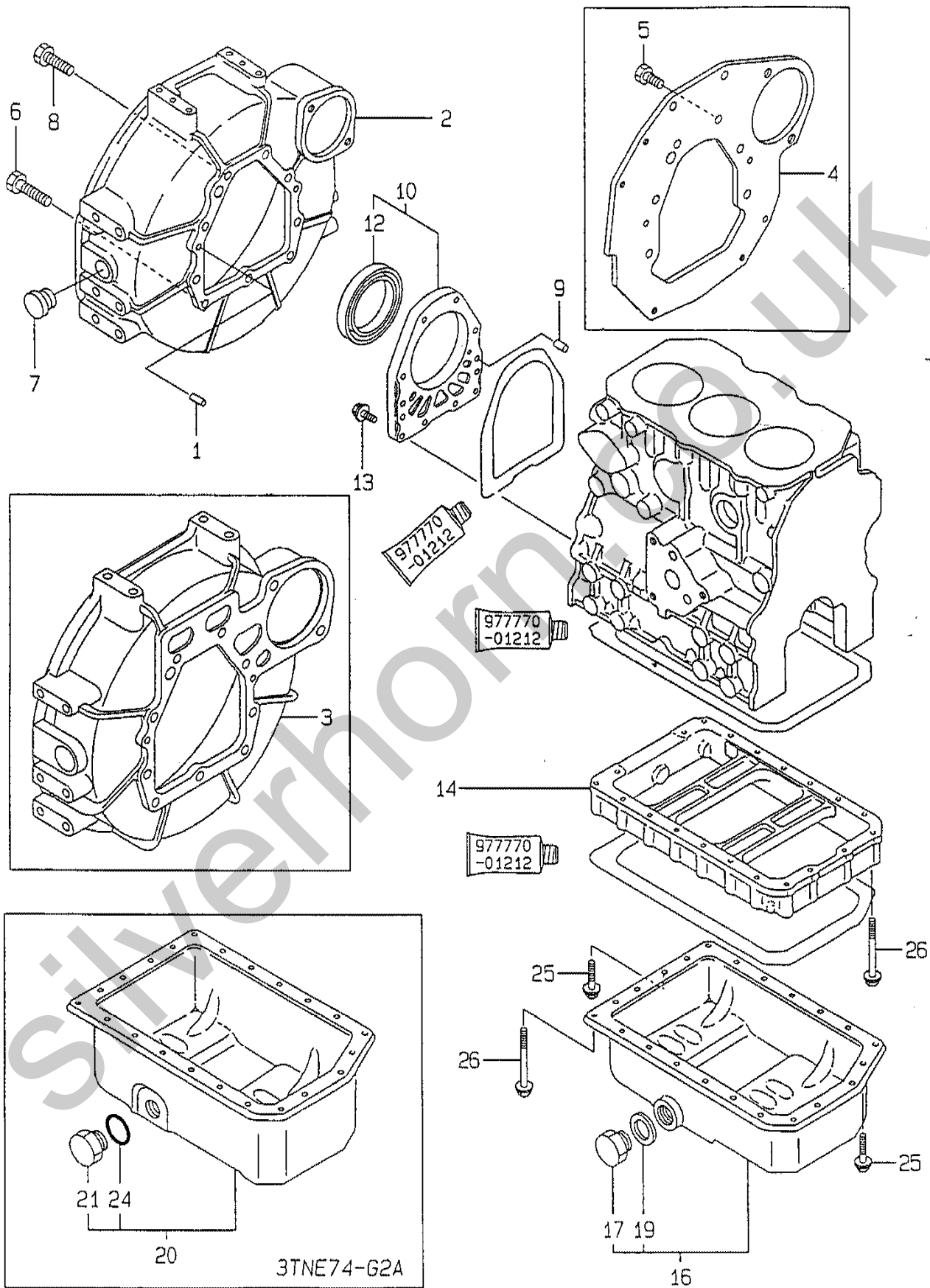

+-----+
 I 1B04 I
 I(1B01)I
 +-----+
 Y00R4520

(3) FLYWHEEL HOUSING & OIL SUMP

(A)=3TNE74-SA (D)=
 (B)=3TNE74-G2A (E)=
 (C)= (F)=

REF. NO.	LEV. 0	PART NO.	DESCRIPTION	-----Q'TY-----						I P/U A R
				(A)	(B)	(C)	(D)	(E)	(F)	
1	.	129100-01580	PARALLEL PIN 8X16	2	2					
2	.	119280-01600	FLANGE, MOUNTING	1	1					(1)
3	.	119600-01600	HOUSING, FLYWHEEL	1	1					(2)
4	.	119621-01611	REAR PLATE	1	1					(3)
5	.	26116-100202	BOLT M10X 20 PLATED	8	8					(3)
6	.	121120-01620	BOLT M 10X 28	3	3					(4)
7	.	119620-01750	CAP, FLYWHEEL COVER	1	1					(4)
8	.	26206-100252	BOLT M10X25	6	6					(4)
9	.	119620-01620	PARALLEL PIN 6X10	2	2					
10	.	119660-01640	CASE ASSY, OIL SEAL	1	1					
12	..	124085-02220	SEAL, OIL	1	1					
13	.	26106-060222	BOLT M 6X 22 PLATED	10	10					
14	.	119600-01722	SPACER, OIL SUMP	1	1					
16	.	719631-01540	SUMP ASSY, LUB. OIL	1						
17	..	119640-01640	DRAIN PLUG M22	1						
19	..	22190-220002	SEAL WASHER 22S	1						
20	.	119600-01770	SUMP ASSY, LUB. OIL		1					
21	..	171301-01640	PLUG M22		1					
24	..	24341-000250	O-RING 1A S-25.0		1					
25	.	26106-060122	BOLT M 6X 12 PLATED	3	3					
26	.	26106-060452	BOLT M 6X 45 PLATED	20	20					

----- REMARKS -----

I (1) FOR SAE GENE(G2A FOR STD),
 I SAE CLUTCH(FOR STD) FOR -SA.
 I (2) FOR SEMI SAE#5.
 I (3) FOR BACK PLATE.
 I (4) FOR SAE GENE(G2A FOR STD)/
 I SEMI SAE#5, SAE CLUTCH(FOR STD)
 I FOR -SA.

4. CYLINDER HEAD & BONNET

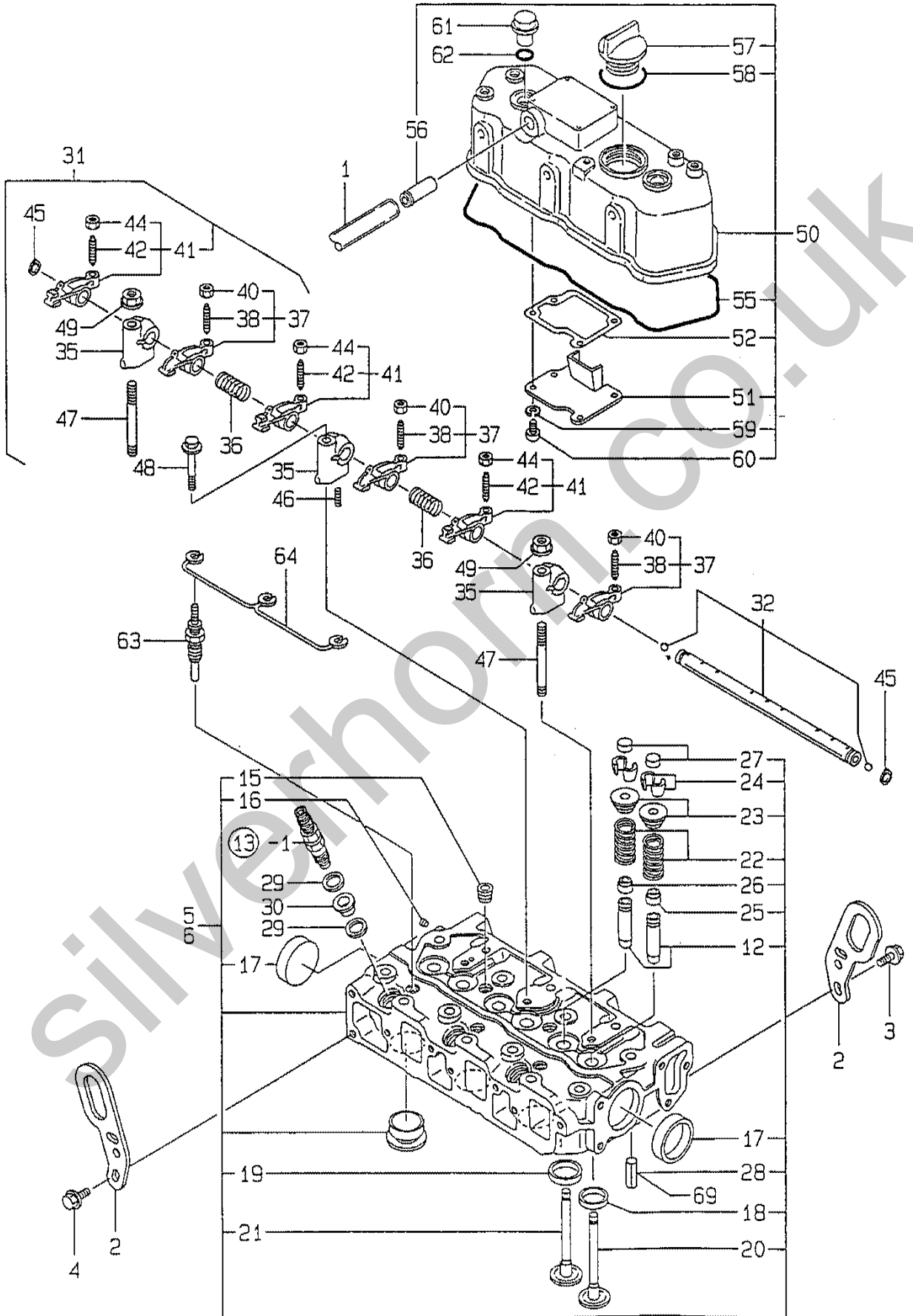

+-----+
 I 1B05 I
 I(1B01)I
 +-----+
 YDOR4520

(4) CYLINDER HEAD & BONNET

(A)=3TNE74-SA (D)=
 (B)=3TNE74-G2A (E)=
 (C)= (F)=

REF. NO.	LEV. 0	PART NO.	DESCRIPTION	-----Q'TY----- I P/U A R					
				(A)	(B)	(C)	(D)	(E)	(F)
1	.	23065-120500	PIPE, VINYL 12X 500	1	1				
2	.	119260-07900	LIFTER, ENGINE	2	2				
3	.	26106-080142	BOLT M 8X 14 PLATED	1	1				
4	.	26106-080142	BOLT M 8X 14 PLATED	2	2				
5	.	719623-11710	HEAD ASSY, CYLINDER	1					
6	.	719623-11700	HEAD ASSY, CYLINDER		1				
12	..	119620-11801	GUIDE, VALVE	6	6				(1)
15	..	121850-11860	PLUG PT1/4	2	2				
16	..	27221-050080	PLUG 5X 8	1	1				
17	..	27241-400000	PLUG 40	2	2				
18	..	119623-11080	SEAT, SUCTION VALVE	3					
19	..	119620-11090	SEAT, EXHAUST VALVE	3					
20	..	119623-11100	VALVE, INTAKE	3	3				
21	..	119620-11110	VALVE, EXHAUST	3	3				
22	..	119620-11120	SPRING, VALVE	6	6				
23	..	119620-11180	RETAINER, SPRING	6	6				
24	..	27310-070000	COTTER	6	6				
25	..	124160-11340	SEAL, VALVE STEM	3	3				(G)
26	..	124950-11340	SEAL, VALVE STEM	3	3				(G)
27	..	104211-11370	CAP, VALVE	6	6				
28	..	22351-060012	SPRING PIN 6X12		2				
29	.	119600-11460	GASKET, NOZZLE	6	6				(G)
30	.	119600-11450	PROTECTOR, NOZZLE	3	3				(G)
31	.	119620-11200	SUPPORT ASSY, ARM	1	1				
32	..	119620-11240	SHAFT ASSY, ROCKER	1	1				
35	..	119620-11260	SUPPORT, ROCKER ARM	3	3				
36	..	119620-11280	SPRING	2	2				
37	..	719620-11650	ARM ASSY, ROCKER	3	3				
38	...	105010-11230	SCREW, VALVE	3	3				
40	...	26756-060002	LOCK NUT M 6 PLATED	3	3				
41	..	719620-11660	ARM ASSY, ROCKER	3	3				
42	...	105010-11230	SCREW, VALVE	3	3				
44	...	26756-060002	LOCK NUT M 6 PLATED	3	3				
45	..	22242-000120	CIRCLIP 12	2	2				
46	..	26979-050162	SCREW M 5X16	1	1				
47	.	119620-11350	STUD	2	2				
48	.	26106-080452	BOLT M 8X 45 PLATED	1	1				
49	.	26366-080002	NUT M 8	2	2				
50	.	119620-11330	BONNET ASSY, (NON-ASB)	1	1				
51	..	119620-03020	PLATE, SHELTER	1	1				
52	..	119620-03031	GASKET, (NON-ASB.)	1	1				(G)
55	..	119620-11310	GASKET, BONNET	1	1				(G)
56	..	119620-11390	JOINT	1	1				
57	..	124160-01751	CAP, LUB.OIL SUPPLY	1	1				
58	..	24311-000320	O-RING 1A P-32.0	1	1				(G)
59	..	22217-050000	SPRING WASHER 5	4	4				
60	..	26557-050102	SCREW M 5X 10	4	4				
61	.	124160-11360	KNOB	2	2				
62	.	24311-000120	O-RING 1A P 12.0	2	2				(G)
63	.	129795-77800	PLUG, GLOW	3	3				
64	.	119620-77820	CONNECTOR, GLOW PLUG	1	1				
69	.	22351-060012	SPRING PIN 6X12	2					

5. SUCTION MANIFOLD & AIR CLEANER

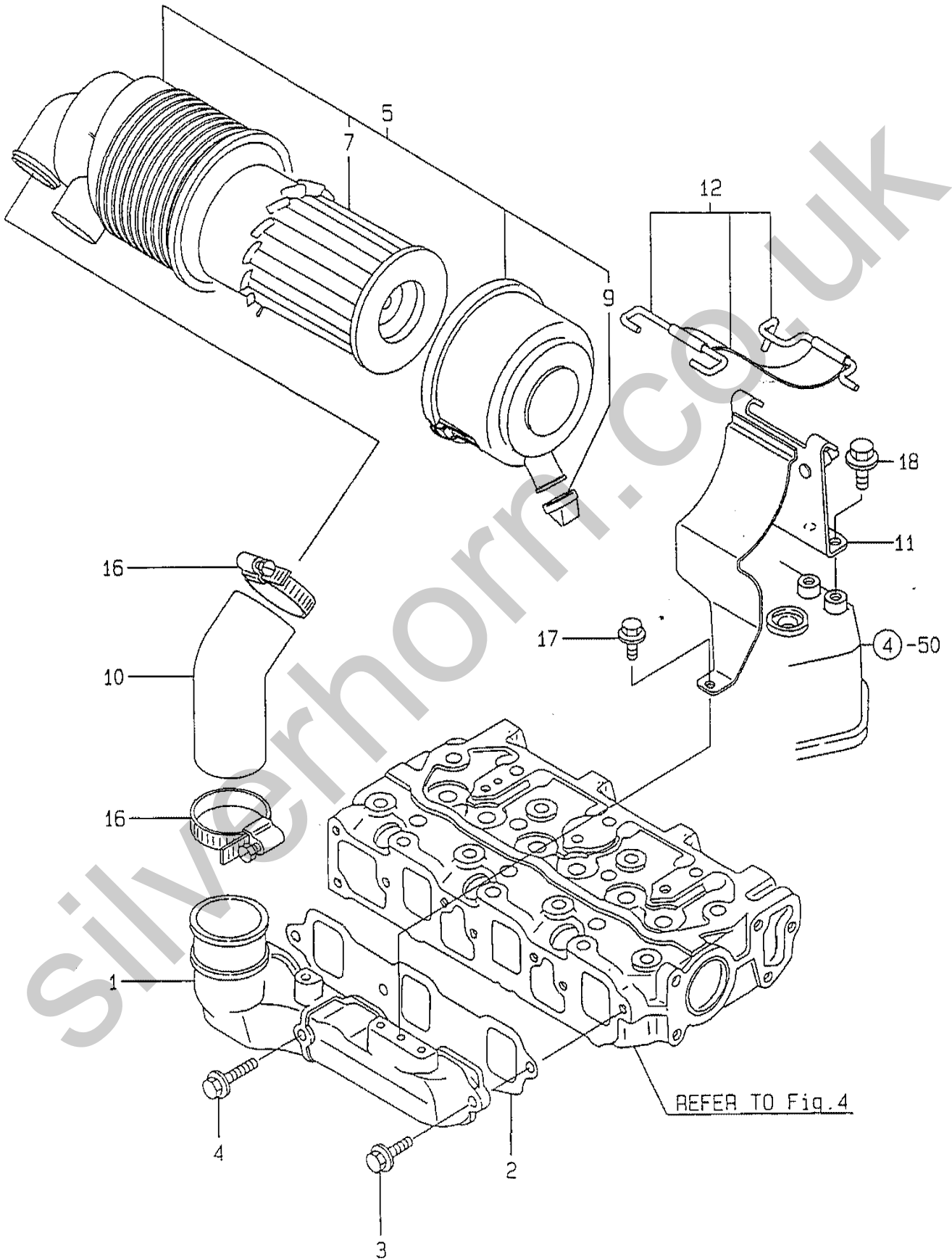

+-----+
 I 1B07 I
 I(1B01)I
 +-----+
 Y00R4520

(5) SUCTION MANIFOLD & AIR CLEANER

(A)=3TNE74-SA (D)=
 (B)=3TNE74-G2A (E)=
 (C)= (F)=

REF. NO.	LEV. 0	PART NO.	DESCRIPTION	-----Q'TY-----						I P/U A R
				(A)	(B)	(C)	(D)	(E)	(F)	
1	.	119660-12101	MANIFOLD,AIR INTAKE	1	1					
2	.	119660-12111	GASKET, SUC.MANIFOLD	1	1					(G)
3	.	26106-060162	BOLT M 6X 16 PLATED	2	2					
4	.	26106-060402	BOLT M 6X 40 PLATED	1	1					
5	.	119653-12500	CLEANER ASSY, AIR	1	1					
7	..	119655-12560	ELEMENT	1	1					
9	..	119808-12540	VALVE, UNLOADER	1	1					
10	.	119653-12550	PIPE, AIR INTAKE	1	1					
11	.	119653-12600	SUPPORT,AIR CLEANER	1	1					
12	.	119865-12600	STAY	1	1					
16	.	23000-054000	CLAMP 54	2	2					
17	.	26106-060122	BOLT M 6X 12 PLATED	1	1					
18	.	26106-080142	BOLT M 8X 14 PLATED	2	2					

----- REMARKS -----

I (G) THESE PARTS ARE SOLD BY FIG.20,
 I REF.NO.1,2.

6. EXHAUST MANIFOLD & SILENCER

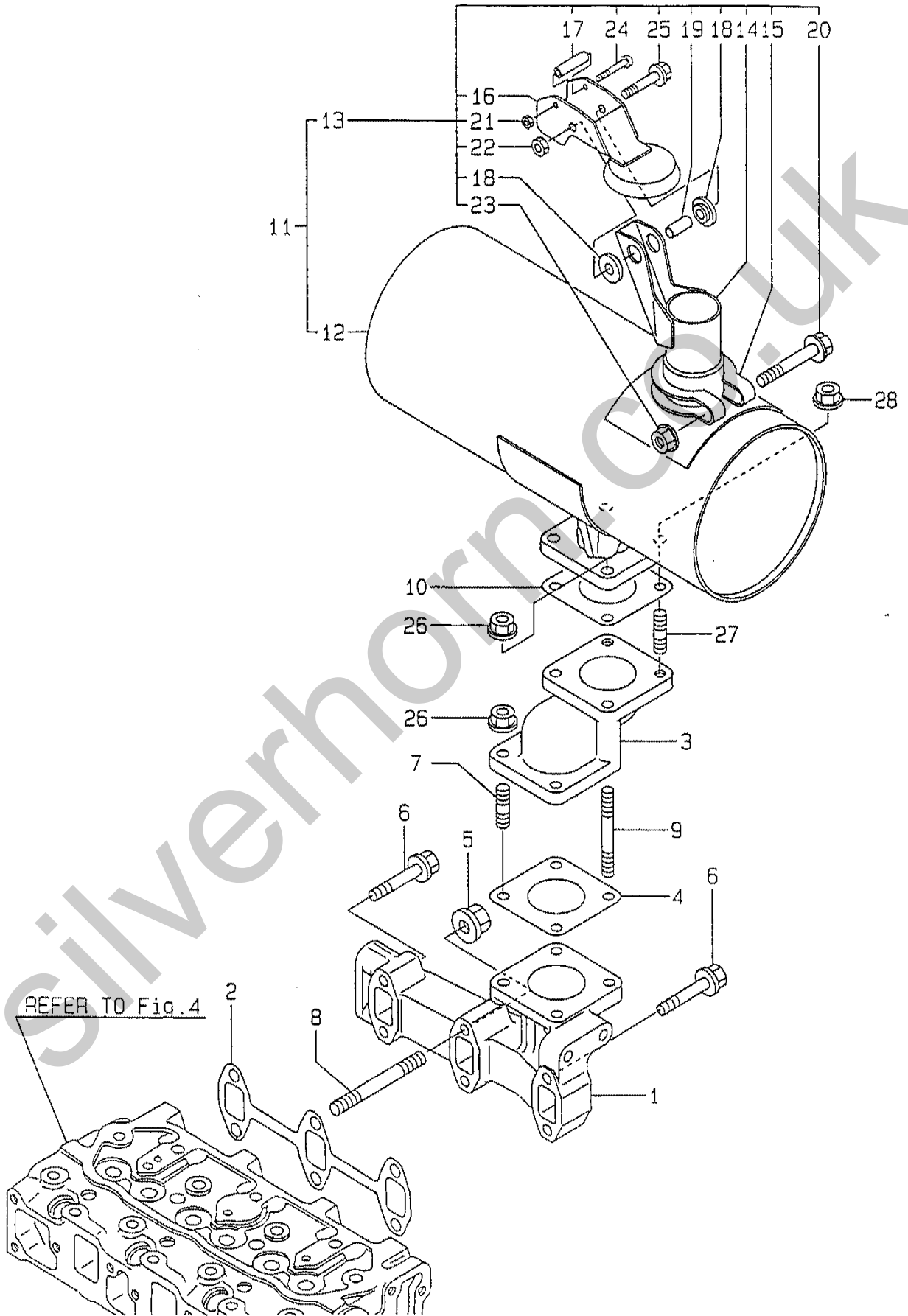

+-----+
 I 1B08 I
 I(1B01)I
 +-----+
 Y00R4520

(6) EXHAUST MANIFOLD & SILENCER

(A)=3TNE74-SA (D)=
 (B)=3TNE74-G2A (E)=
 (C)= (F)=

REF. NO.	LEV. 0	PART NO.	DESCRIPTION	-----Q'TY-----						I P/U A R
				(A)	(B)	(C)	(D)	(E)	(F)	
1	.	119631-13101	MANIFOLD, EXHAUST	1	1					
2	.	119620-13110	GASKET, EXH.MANIFOLD	1	1					(G)
3	.	119840-13150	PIPE, EXHAUST	1	1					
4	.	121000-13201	GASKET, SILENCER	1	1					(G)
5	.	194990-22050	NUT W/WASHER 8	2	2					
6	.	26106-080402	BOLT M 8X 40 PLATED	4	4					
7	.	26216-080222	STUD M 8X 22 PLATED	2	2					
8	.	26216-080552	STUD M 8X 55 PLATED	2	2					
9	.	26216-080702	STUD M 8X 70 PLATED	2	2					
10	.	121000-13201	GASKET, SILENCER	1	1					(G)
11	.	119620-13501	SILENCER	1	1					
12	..	119620-13510	MUFFLER BODY ASSY	1	1					
13	..	119620-13520	TAILPIPE ASSY	1	1					
14	...	119620-13560	TAILPIPE	1	1					
15	...	124664-13580	CLAMP	1	1					
16	...	119358-13640	RAINCAP, MUFFLER	1	1					
17	...	121855-13821	SPACER(A)	1	1					
18	...	121855-13830	SPACER(B)	2	2					
19	...	123500-13840	SPACER(C)	1	1					
20	...	26106-080552	BOLT M 8X 55 PLATED	1	1					
21	...	26347-040002	U-NUT M 4	1	1					
22	...	26347-060002	U NUT 6	1	1					
23	...	26366-080002	NUT M 8	1	1					
24	...	26557-040352	SCREW M 4X 35	1	1					
25	...	26106-060402	BOLT M 6X 40 PLATED	1	1					
26	.	194990-22050	NUT W/WASHER 8	4	4					
27	.	26216-080222	STUD M 8X 22 PLATED	2	2					
28	.	194990-22050	NUT W/WASHER 8	2	2					

REMARKS

I (G) THESE PARTS ARE SOLD BY FIG.20,
 I REF.NO.1,2.

7. CAMSHAFT & DRIVING GEAR

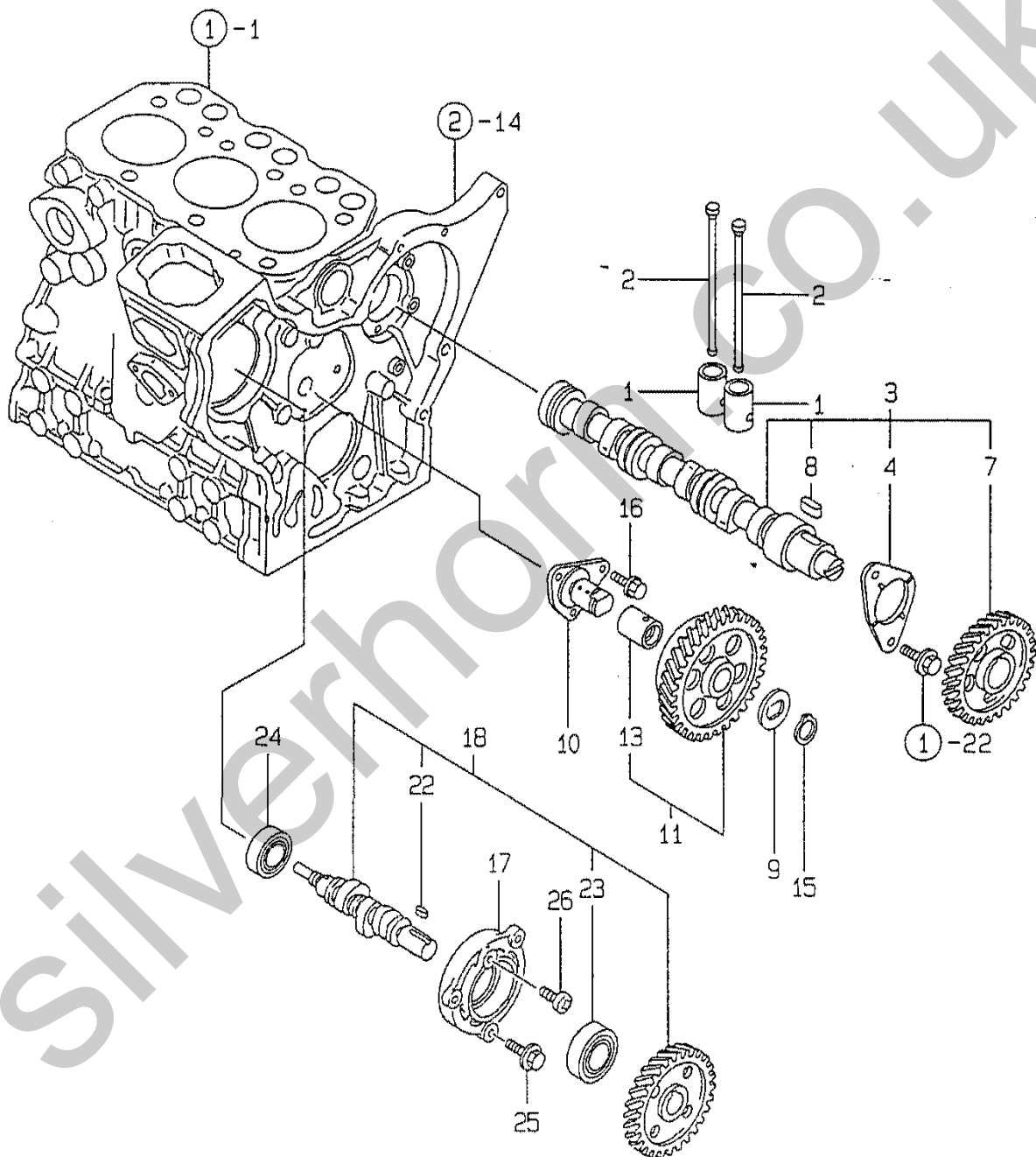

+-----+
 I 1809 I
 I(1801)I
 +-----+
 Y00R4520

(7) CAMSHAFT & DRIVING GEAR

(A)=3TNE74-SA (D)=
 (B)=3TNE74-G2A (E)=
 (C)= (F)=

REF. NO.	LEV. 0	PART NO.	DESCRIPTION	-----Q'TY-----						I P/U A R
				(A)	(B)	(C)	(D)	(E)	(F)	
1	.	119620-14200	TAPPET	6	6					
2	.	119620-14401	ROD, PUSH	6	6					
3	.	119629-14580	CAMSHAFT ASSY	1	1					
4	..	119620-02450	BEARING, THRUST	1	1					
7	..	119620-14100	GEAR, CAMSHAFT	1	1					
8	..	22512-040120	KEY 4X 12	1	1					
9	.	119660-25022	RETAINER, IDLE GEAR	1	1					
10	.	119660-25052	SHAFT, IDLE GEAR	1	1					
11	.	119620-25102	GEAR W/BUSH, IDLE	1	1					
13	..	119620-25912	BUSH	1	1					(1)
15	.	22242-000200	CIRCLIP 20	1	1					
16	.	26106-060122	BOLT M 6X 12 PLATED	3	3					
17	.	119660-01821	BEARING, FUEL CAM.	1	1					
18	.	719660-14590	CAM ASSY, F.I. PUMP	1	1					
22	..	22512-040120	KEY 4X 12	1	1					
23	..	24102-063034	BALL BEARING 6303U	1	1					
24	.	24101-062034	BALL BEARING	1	1					
25	.	26106-060162	BOLT M 6X 16 PLATED	3	3					
26	.	26587-080102	SCREW M 8X 10	1	1					

REMARKS

I(1) REPAIR PART.

8. CRANKSHAFT & PISTON

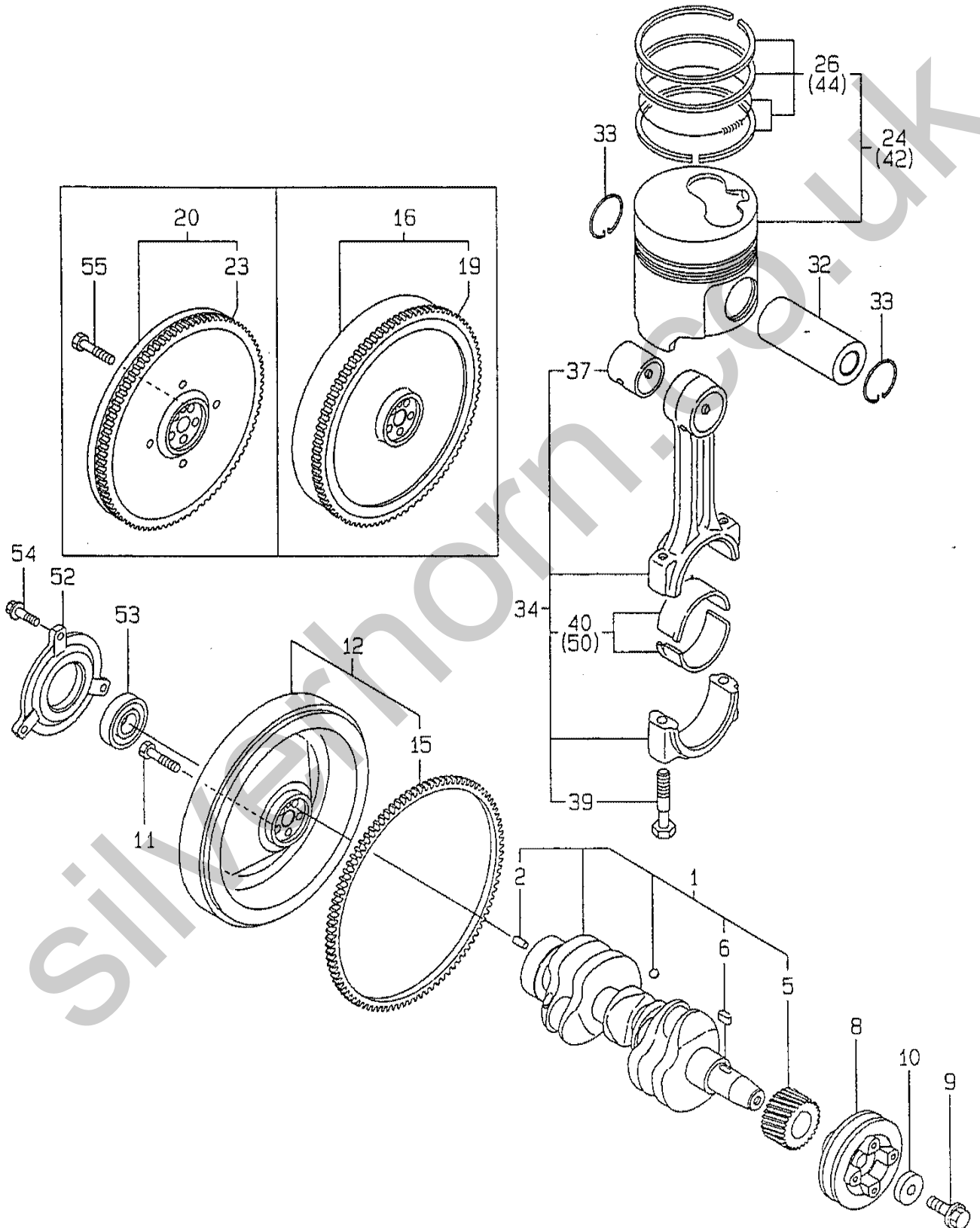

+-----+
 I 1B10 I
 I(1B01)I
 +-----+
 YDOR452D

(8) CRANKSHAFT & PISTON

(A)=3TNE74-SA (D)=
 (B)=3TNE74-G2A (E)=
 (C)= (F)=

REF. NO.	LEV. 0	PART NO.	DESCRIPTION	-----Q'ITY-----						I P/U A R
				(A)	(B)	(C)	(D)	(E)	(F)	
1	.	119623-21700	CRANKSHAFT ASSY	1	1					
2	..	129100-01580	PARALLEL PIN 8X16	1	1					
5	..	119644-21200	CRANKGEAR	1	1					
6	..	22512-040120	KEY 4X 12	1	1					
8	.	119660-21651	V-PULLEY	1	1					
9	.	119621-21680	BOLT M12X1.25, FLANGE	1	1					
10	.	119620-21941	WASHER	1	1					
11	.	121111-21501	BOLT, FLYWHEEL	5	5					(1)
12	.	119688-21590	FLYWHEEL CMP	1	1					(2)
15	..	119865-21600	GEAR, RING	1	1					
16	.	119600-21580	FLYWHEEL ASSY	1	1					(3)
19	..	119865-21600	GEAR, RING	1	1					
20	.	119620-21591	FLYWHEEL W/RING GEAR	1	1					(4)
23	..	124060-21600	GEAR, RING	1	1					
24	.	119623-22080	PISTON W/RING	3	3					
26	..	119623-22500	RING SET, PISTON	3	3					
32	.	114350-22301	PIN, PISTON D=21	3	3					
33	.	22252-000210	CIRCLIP 21	6	6					
34	.	719620-23100	ROD ASSY, CONNECTING	3	3					
37	..	119620-23910	BUSH, PISTON PIN	3	3					(5)
39	..	105225-23200	BOLT, ROD	6	6					
40	..	719620-23600	BEARING, CRANKPIN	3	3					
42	.	119623-22900	PISTON W/RING OS=.25	3	3					(6)
44	..	119623-22950	RING SET OS=0.25	3	3					(6)
50	.	719620-23610	BEARING, PIN U.S.=0.25	3	3					(7)
52	.	119888-21450	RETAINER, BEARING	1						(8)
53	.	24107-062054	BALL BEARING	1						(8)
54	.	26106-080222	BOLT M 8X 22 PLATED	3						(8)
55	.	119620-21500	BOLT, FLYWHEEL	5	5					(4)

REMARKS

- I (1) FOR SAE GENE(G2A FOR STD)/SEMI
- I SAE#5, SAE CLUTCH(FOR STD)FOR -SA.
- I (2) FOR SAE GENE(G2A FOR STD),
- I SAE CLUTCH(FOR STD)FOR -SA.
- I (3) FOR SEMI SAE#5.
- I (4) FOR BACK PLATE.
- I (5) REPAIR PART.
- I (6) OVER-SIZE(O.S=0.25)PART.
- I (7) UNDER-SIZE(U.S=0.25)PART.
- I (8) FOR SAE CLUTCH(FOR STD).

+-----+
 I 1B10 I
 I(1B01)I
 +-----+
 YDOR4520

(8) CRANKSHAFT & PISTON

(A)=3TNE74-SA (D)=
 (B)=3TNE74-G2A (E)=
 (C)= (F)=

REF. NO.	LEV. 0	PART NO.	DESCRIPTION	-----Q'TY-----						I P/U A R
				(A)	(B)	(C)	(D)	(E)	(F)	
1	.	119623-21700	CRANKSHAFT ASSY	1	1					
2	..	129100-01580	PARALLEL PIN 8X16	1	1					
5	..	119644-21200	CRANKGEAR	1	1					
6	..	22512-040120	KEY 4X 12	1	1					
8	.	119660-21651	V-PULLEY	1	1					
9	.	119621-21680	BOLT M12X1.25, FLANGE	1	1					
10	.	119620-21941	WASHER	1	1					
11	.	121111-21501	BOLT, FLYWHEEL	5	5					(1)
12	.	119688-21590	FLYWHEEL CMP	1	1					(2)
15	..	119865-21600	GEAR, RING	1	1					
16	.	119600-21580	FLYWHEEL ASSY	1	1					(3)
19	..	119865-21600	GEAR, RING	1	1					
20	.	119620-21591	FLYWHEEL W/RING GEAR	1	1					(4)
23	..	124060-21600	GEAR, RING	1	1					
24	.	119623-22080	PISTON W/RING	3	3					
26	..	119623-22500	RING SET, PISTON	3	3					
32	.	114350-22301	PIN, PISTON D=21	3	3					
33	.	22252-000210	CIRCLIP 21	6	6					
34	.	719620-23100	ROD ASSY, CONNECTING	3	3					
37	..	119620-23910	BUSH, PISTON PIN	3	3					(5)
39	..	105225-23200	BOLT, ROD	6	6					
40	..	719620-23600	BEARING, CRANKPIN	3	3					
42	.	119623-22900	PISTON W/RING OS=.25	3	3					(6)
44	..	119623-22950	RING SET OS=0.25	3	3					(6)
50	.	719620-23610	BEARING, PIN U.S.=0.25	3	3					(7)
52	.	119888-21450	RETAINER, BEARING	1						(8)
53	.	24107-062054	BALL BEARING	1						(8)
54	.	26106-080222	BOLT M 8X 22 PLATED	3						(8)
55	.	119620-21500	BOLT, FLYWHEEL	5	5					(4)

----- REMARKS -----

- 1(1) FOR SAE GENE(G2A FOR STD)/SEMI SAE#5, SAE CLUTCH(FOR STD)FOR -SA.
- 1(2) FOR SAE GENE(G2A FOR STD), SAE CLUTCH(FOR STD)FOR -SA.
- 1(3) FOR SEMI SAE#5.
- 1(4) FOR BACK PLATE.
- 1(5) REPAIR PART.
- 1(6) OVER-SIZE(O.S=0.25)PART.
- 1(7) UNDER-SIZE(U.S=0.25)PART.
- 1(8) FOR SAE CLUTCH(FOR STD).

+-----+
 I 1B11 I
 I(1B01)I
 +-----+
 Y00R4520

(9) LUB.OIL SYSTEM

(A)=3TNE74-SA (D)=
 (B)=3TNE74-G2A (E)=
 (C)= (F)=

REF. NO.	LEV. 0	PART NO.	DESCRIPTION	-----Q'TY-----						I P/U A R
				(A)	(B)	(C)	(D)	(E)	(F)	
1	.	119660-32001	PUMP ASSY, LUB. OIL	1	1					
11	.	119660-32020	GASKET, L.O.PUMP	1	1					(G)
12	.	26450-060202	BOLT M 6X 20	3	3					
13	.	121520-34810	GUIDE, DIPSTICK	1	1					
14	.	119600-34800	DIPSTICK, LUB. OIL	1						
15	.	119600-34820	DIPSTICK, LUB. OIL		1					
16	.	119660-35102	BRACKET, OIL FILTER	1	1					
17	.	119660-35113	GASKET, (NON-ASB.)	1	1					(G)
18	.	119305-35150	FILTER, LUB. OIL	1	1					
19	.	119660-35300	VALVE ASSY, OIL PRESS	1	1					
27	.	129150-35350	NUT	1	1					
28	.	24311-000160	O-RING 1A P-16.0	1	1					(G)
29	.	26106-080202	BOLT M 8X 20 PLATED	3	3					
30	.	119600-35081	PIPE ASSY, LUB.OIL	1						
31	.	119600-35091	PIPE ASSY, OIL INTAKE		1					
32	.	24311-000120	O-RING 1A P 12.0	1	1					(G)
33	.	26106-060102	BOLT M 6X 10 PLATED	2	2					
34	.	124160-39450	SWITCH, OIL PRESSURE	1	1					
35	.	171375-39600	DAMPER ASSY	1	1					(1)
36	..	129470-39610	DAMPER	1	1					(1)
37	..	23161-020100	BUSH PT1/4X1/8	1	1					(1)
38	.	144626-91560	TACHO UNIT	1	1					(1)
39	.	119642-33030	COOLER, OIL		1					
40	.	119642-33100	BRACKET		1					
41	.	119265-44400	JOING, PIPE M16		1					
42	.	129122-44480	JOINT		1					
43	.	119642-49030	PIPE		1					
44	.	129403-49050	PIPE, COOLER-C.W.PUMP		1					
45	.	23000-022000	CLAMP 22		4					
46	.	23871-030000	PLUG PT3/8, SCREW		1					
47	.	24321-000600	O-RING 1A G-60.0		1					(G)
48	.	24321-000700	O-RING 1A G-70.0		1					(G)

----- REMARKS -----

I(1) FOR PANEL(METER).
 I(G) THESE PARTS ARE SOLD BY FIG.20,
 I REF.NO.1,2.

10. COOLING WATER SYSTEM

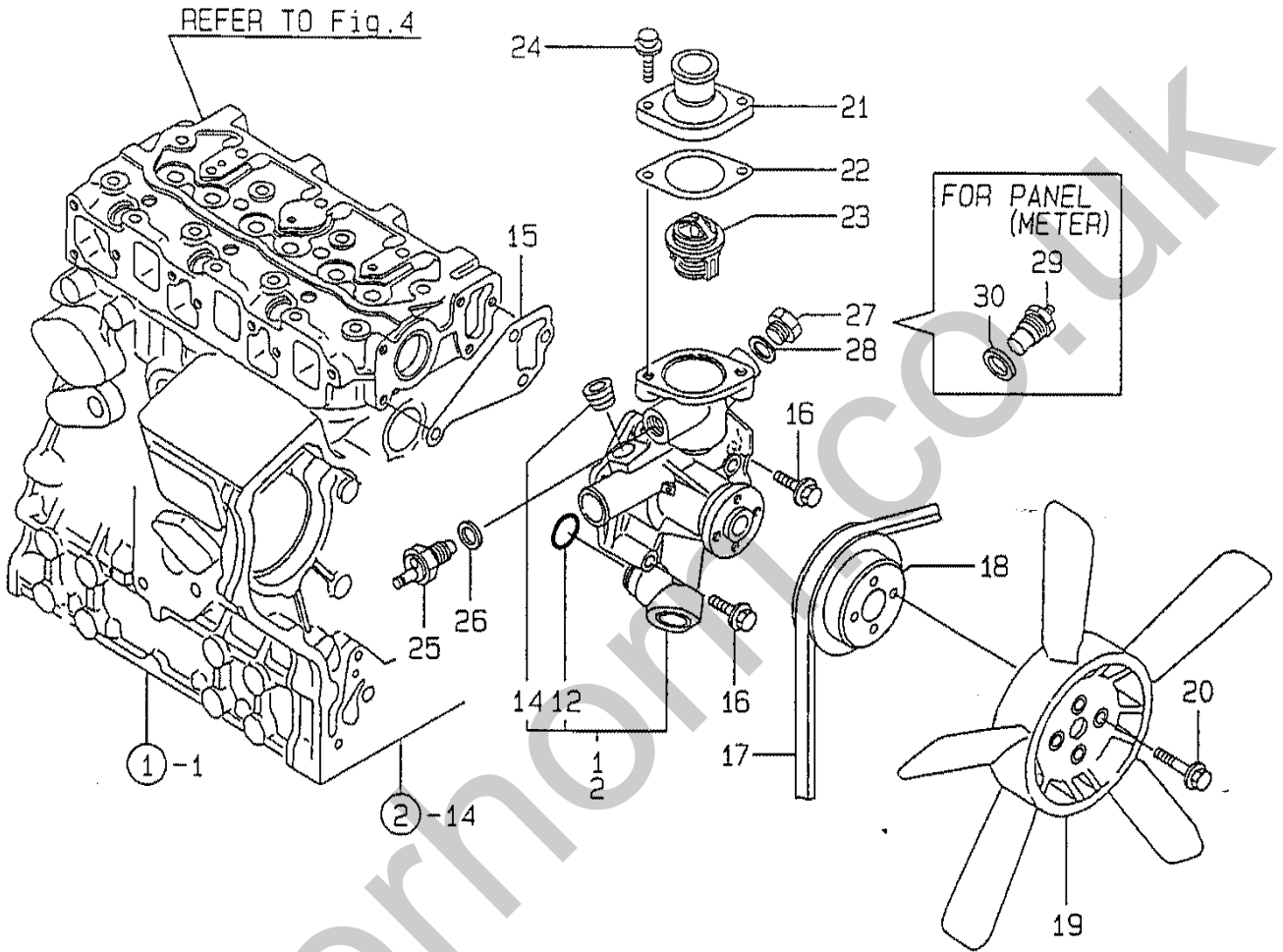

+-----+
 I 1B12 I
 I(1B01)I
 +-----+
 Y0DR4520

(10) COOLING WATER SYSTEM

(A)=3TNE74-SA (D)=
 (B)=3TNE74-G2A (E)=
 (C)= (F)=

REF. NO.	LEV. 0	PART NO.	DESCRIPTION	-----Q'TY-----						I P/U A R
				(A)	(B)	(C)	(D)	(E)	(F)	
1	.	119660-42004	PUMP ASSY,CW(NON-ASB	1						
2	.	119642-42000	PUMP ASSY,COOL.WATE		1					
12	..	119620-42320	O-RING	1	1					
14	..	23871-030000	PLUG PT3/8,SCREW	1						
15	.	119620-42020	GASKET, C.W. PUMP	1	1					(G)
16	.	26106-080452	BOLT M 8X 45 PLATED	4	4					
17	.	119650-42291	V-BELT FM=35.0	1	1					
18	.	119660-42350	V-PULLEY, C.W. PUMP	1	1					
19	.	124700-44740	FAN, COOLING	1	1					
20	.	26014-060162	BOLT M 6X 16	4	4					
21	.	129350-49530	COVER, THERMOSTAT	1	1					
22	.	129350-49541	GASKET, (NON-ASB.)	1	1					(G)
23	.	129350-49800	THERMOSTAT (71°C	1	1					
24	.	26106-080202	BOLT M 8X 20 PLATED	2	2					
25	.	121250-44901	SWITCH, THERMO(110°C	1	1					
26	.	124465-44950	GASKET 16	1	1					(G)
27	.	121450-42450	PLUG M16	1	1					
28	.	124465-44950	GASKET 16	1	1					(G)
29	.	124250-49351	THERMOMETER	1	1					(1)
30	.	129150-49360	GASKET 10	1	1					(1)

----- REMARKS -----

I (1) FOR PANEL (METER).
 I (G) THESE PARTS ARE SOLD BY FIG.20,
 I REF.NO.1,2.

11. RADIATOR

REFER TO Fig.3

REFER TO Fig.10

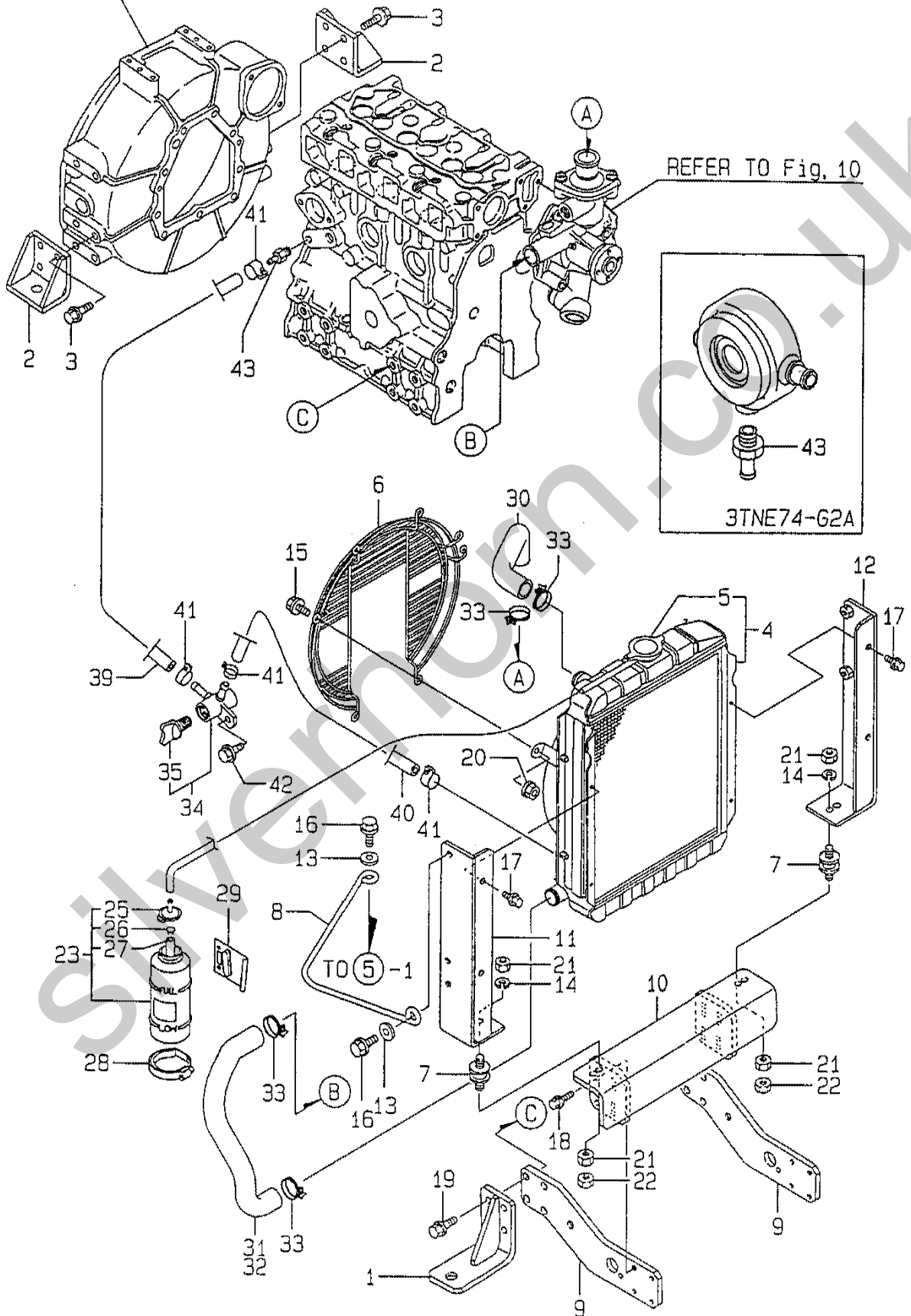

+-----+
 I 1813 I
 I(1801)I
 +-----+
 Y00R4520

(11) RADIATOR

(A)=3TNE74-SA (D)=
 (B)=3TNE74-G2A (E)=
 (C)= (F)=

REF. NO.	LEV. 0	PART NO.	DESCRIPTION	-----Q'TY----- I P/U A R					
				(A)	(B)	(C)	(D)	(E)	(F)
1	.	119288-08100	BRACKET (A), ENGINE	2					
2	.	119888-08110	BRACKET (B), ENGINE	2					
3	.	26106-100202	BOLT M10X 20 PLATED	8					
4	.	119621-44500	RADIATOR	1	1				
5	..	119259-44570	CAP, RADIATOR	1	1				
6	.	119621-44560	FAN-GUARD	1	1				
7	.	121400-44650	ABSORBER, SHOCK	2					
8	.	119688-44940	RETAINING BAR	1					
9	.	119688-44950	BRACKET (A)	2					
10	.	119688-44961	BRACKET (B), RADIATOR	1					
11	.	119688-44971	BRACKET (L)	1					
12	.	119688-44981	BRACKET (R)	1					
13	.	22137-080000	WASHER 8, POLISHED	2					
14	.	22217-100000	SPRING WASHER 10	2					
15	.	26106-080122	BOLT M 8X 12 PLATED	6	6				
16	.	26106-080162	BOLT M 8X 16 PLATED	2					
17	.	26106-080202	BOLT M 8X 20 PLATED	4					
18	.	26106-080252	BOLT M 8X 25 PLATED	8					
19	.	26116-100302	BOLT M10X 30 PLATED	8					
20	.	26366-080002	NUT M 8	6	6				
21	.	26716-100002	NUT M10	4					
22	.	26756-100002	LOCK NUT M10 PLATED	2					
23	.	124450-44510	TANK	1	1				
25	..	124450-44530	CAP	1	1				
26	..	124450-44560	CLAMP	1	1				
27	..	23061-070230	PIPE 7X 230	1	1				
28	.	124450-44550	CLAMP, SUB-TANK	1	1				
29	.	121256-44600	BRACKET, SUB-TANK	1	1				
30	.	119688-49010	PIPE (A), C. WATER	1	1				
31	.	119645-49020	PIPE (B), C. WATER	1	1				
32	.	119280-49020	PIPE (B), C. WATER	1					
33	.	23010-038000	CLAMP 38	4	4				
34	.	129150-49100	COCK ASSY, 3-WAY	1	1				
35	..	129150-49080	COCK, DRAIN	1	1				
39	.	121750-49150	PIPE, C. WATER	1					
40	.	121023-49150	HOSE, WATER DRAIN 165	1					
41	.	124766-59050	CLAMP 12	4					
42	.	26106-080162	BOLT M 8X 16 PLATED	1					
43	.	121550-49111	JOINT PT1/4	1	1				

12. FUEL INJECTION PUMP

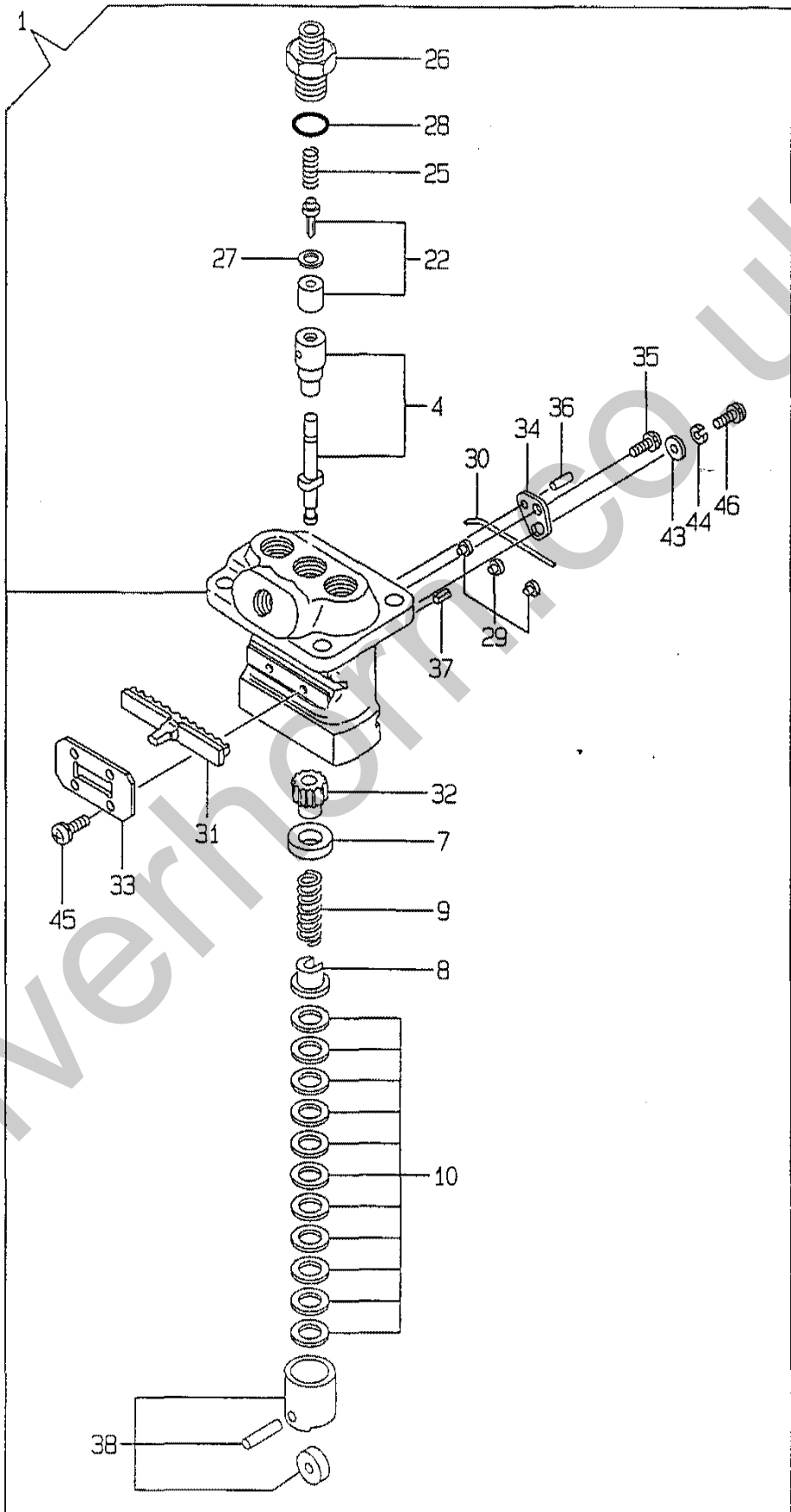

+-----+
 I 1B14 I
 I(1B01)I
 +-----+
 Y00R4520

(12) FUEL INJECTION PUMP

(A)=3TNE74-SA (D)=
 (B)=3TNE74-G2A (E)=
 (C)= (F)=

REF. NO.	LEV. 0	PART NO.	DESCRIPTION	-----Q'TY----- I P/U A R					
				(A)	(B)	(C)	(D)	(E)	(F)
1	.	719621-51100	PUMP ASSY, F.INJECT.	1	1				
4	..	119620-51101	PLUNGER W/BARREL	3	3				
7	..	119620-51170	RETAINER	3	3				
8	..	119620-51180	RETAINER	3	3				
9	..	119620-51190	SPRING, PLUNGER	3	3				
10	..	119620-51250	SHIM PACK	3	3				
22	..	119620-51300	VALVE W/SEAT, DELIV.	3	3				
25	..	105546-51330	SPRING, DELIV. VALVE	3	3				
26	..	119620-51340	HOLDER, DELIV. VALVE	3	3				
27	..	119620-51350	GASKET, DELIVERY	3	3				
28	..	119620-51370	O-RING	3	3				
29	..	119620-51450	GUIDE, PLUNGER	3	3				
30	..	119620-51461	PIN	1	1				
31	..	119660-51500	RACK	1	1				
32	..	119620-51510	PINION	3	3				
33	..	119660-51530	RETAINER, RACK	1	1				
34	..	119620-51650	PLATE	2	2				
35	..	119620-51660	SCREW	2	2				
36	..	119620-51670	PIN	2	2				
37	..	119620-51680	PIN	1	1				
38	..	119620-51700	TAPPET ASSY	3	3				
43	..	22137-040000	WASHER 4, POLISHED	2	2				
44	..	22217-040000	SPRING WASHER 4	2	2				
45	..	26022-040082	SCREW M 4X 8	4	4				
46	..	26587-040102	SCREW M 4X 10	2	2				

13. GOVERNOR

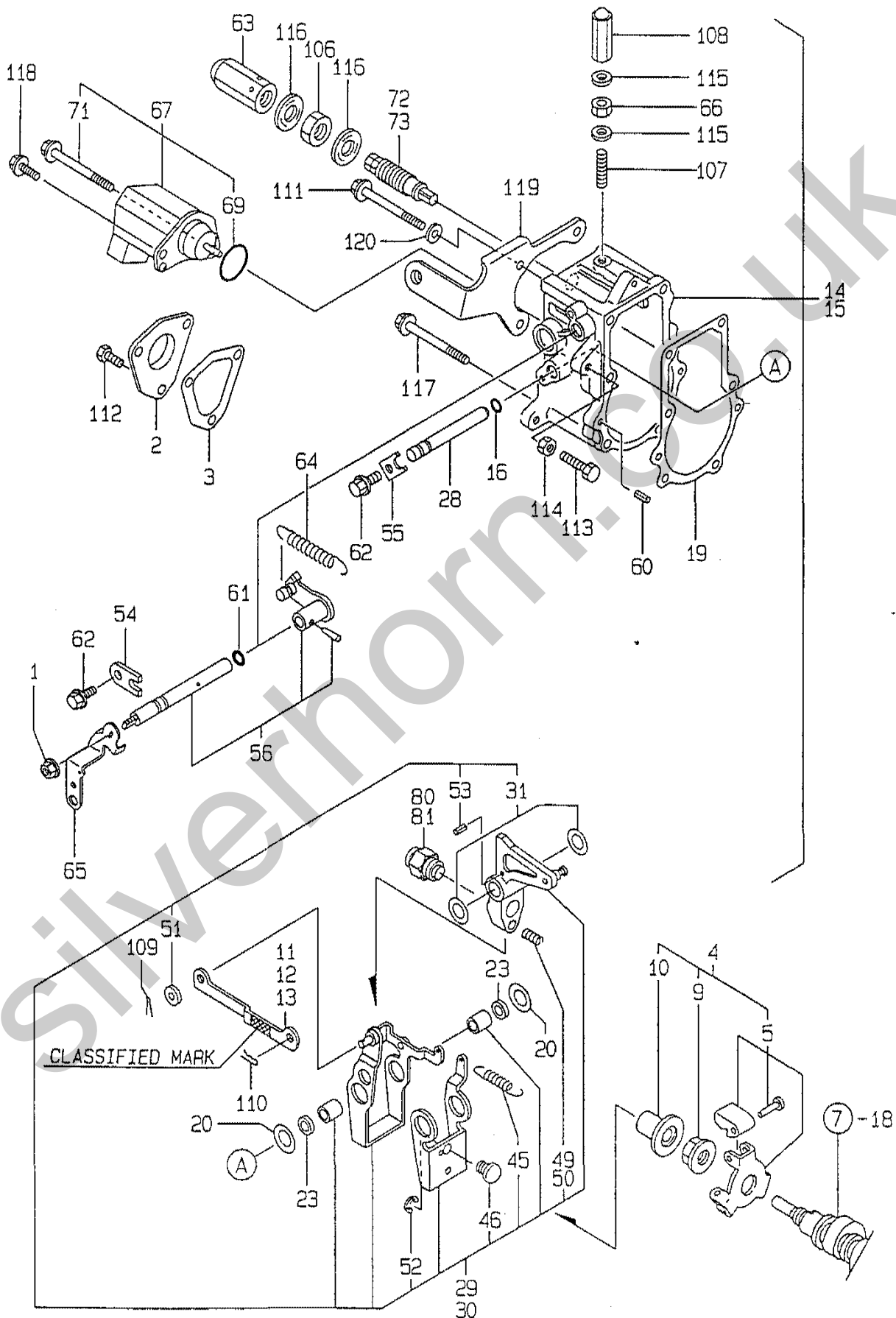

+-----+
 I 1815 I
 I(1801)I
 +-----+
 Y00R4520

(13) GOVERNOR

(A)=3TNE74-SA (D)=
 (B)=3TNE74-G2A (E)=
 (C)= (F)=

REF. NO.	LEV. 0	PART NO.	DESCRIPTION	-----Q'TY-----						I	P	U	A	R
				(A)	(B)	(C)	(D)	(E)	(F)					
1	.	194990-22050	NUT W/WASHER 8	1	1									
2	.	119660-61060	COVER, GOVERNOR CASE	1	1									
3	.	119660-61071	GASKET, (NON-ASB.)	1	1									
4	.	119600-61100	DRIVING SET, GOV.	1	1									
5	..	119600-61200	WEIGHT ASSY, GOV.	1	1									
9	..	119660-61300	NUT, GOVERNOR WEIGHT	1	1									
10	..	119660-61341	SLEEVE, GOVERNOR	1	1									
11	.	119660-61121	LINK L=88.8(NO COLOR)	1	1									(1)
12	.	119660-61140	LINK L=88.6(WHITE)	1	1									(1)
13	.	119660-61150	LINK L=89.0(RED)	1	1									(1)
14	.	119632-61200	CASE ASSY, GOVERNOR	1										
15	.	119288-61200	CASE ASSY, GOVERNOR		1									
16	..	129155-51280	O-RING S6	1	1									
19	..	119660-61052	GASKET, (NON-ASB.)	1	1									
20	..	119660-61460	SHIM SET	1	1									
23	..	129155-61480	SPACER ASSY	2	2									
28	..	119660-61491	SHAFT, GOVERNOR LEVER	1	1									
29	..	119232-61510	LEVER ASSY, GOVERNOR	1										
30	..	119288-61510	LEVER ASSY, GOVERNOR		1									
31	...	174307-51700	SHIM SET	2	2									
45	...	119232-61540	SPRING, LEVER	1	1									
46	...	119600-61541	SHIFTER, P.T.O.	1	1									
49	...	119660-61651	SPRING, STARTING	1										
50	...	119600-61650	SPRING, STARTING		1									
51	...	22117-040000	WASHER 4	1	1									
52	...	22272-000040	CIRCLIP E- 4	1	1									
53	...	22351-030014	SPRING PIN 3X14	1	1									
54	..	119600-61900	RETAINER, SHAFT	1	1									
55	..	119660-61901	RETAINER, SHAFT	1	1									
56	..	119285-66080	SHAFT ASSY, REGULATOR	1	1									
60	..	22351-040010	SPRING PIN 4X10	2	2									
61	..	24341-000070	O-RING 1A S-7.0	1	1									
62	..	26106-060102	BOLT M 6X 10 PLATED	2	2									
63	.	129100-61930	NUT, CAP	1	1									
64	.	119600-66020	SPRING, REGULATOR	1	1									
65	.	119621-66051	LEVER, REGULATOR	1	1									
66	.	124550-66370	LOCK NUT M 6	1	1									
67	.	119653-66500	ENGINE STOP DEVICE	1	1									
69	..	24341-000280	O-RING 1A S-28.0	1	1									
71	..	26106-060952	BOLT M 6X 95 PLATED	1	1									
72	.	119629-66510	TORQUE SPRING ASSY	1										
73	.	119600-66530	TORQUE SPRING ASSY		1									
80	.	119260-66720	ANGLEICH ASSY	1										
81	.	119600-66700	UNGLEICH ASSY		1									
106	.	26776-120002	LOCK NUT M12 PLATED	1	1									
107	.	121575-66830	SCREW, ADJUST	1	1									
108	.	119600-66840	NUT, CAP	1	1									
109	.	22360-040000	SNAP PIN 4	1	1									
110	.	22360-060000	SNAP PIN 6	1	1									
111	.	26106-060702	BOLT M 6X 70 PLATED	2	2									
112	.	26116-050102	BOLT M 5X 10 PLATED	3	3									
113	.	26116-060304	BOLT M 6X 30 PLATED	1	1									
114	.	26756-060002	LOCK NUT M 6 PLATED	1	1									
115	.	22190-060003	SEAL WASHER 6	2	2									

** CONTINUE **

Y100145

13. GOVERNOR

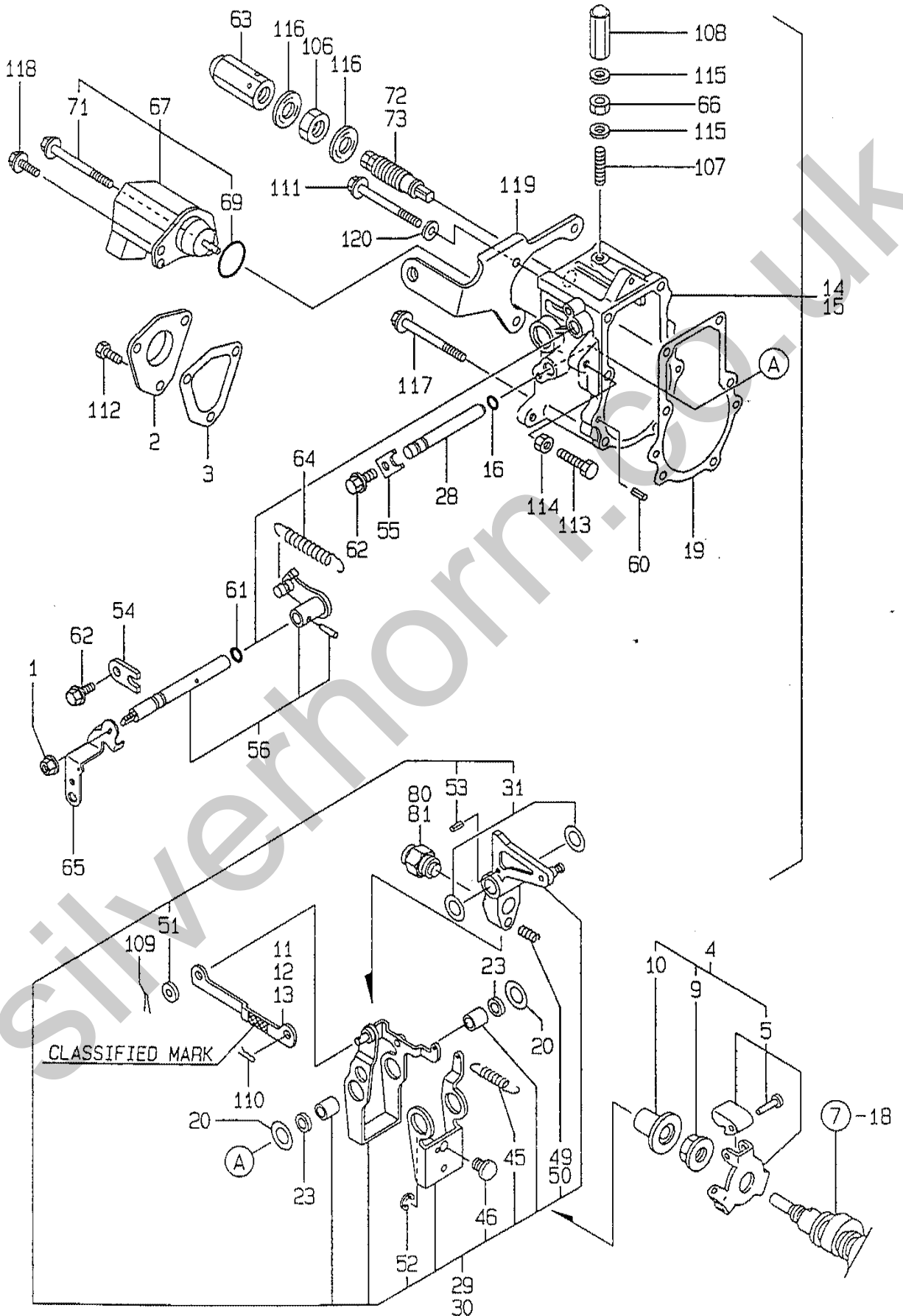

+-----+
| 1B16 |
| (1B01) |
+-----+
Y00R4520

(13) GOVERNOR

(A)=3TNE74-SA (D)=
(B)=3TNE74-G2A (E)=
(C)= (F)=

REF. NO.	LEV. 0	PART NO.	DESCRIPTION	-----Q'TY-----						I	P/U	A	R
				(A)	(B)	(C)	(D)	(E)	(F)				
116	.	22190-120002	SEAL WASHER 12S	2	2								
117	.	26106-060752	BOLT M 6X 75 PLATED	3	3								
118	.	121465-59950	BOLT M 6X 16, PLATED	1	1								
119	.	119288-55900	BRACKET, FUEL FILTER	1	1								
120	.	22111-060000	WASHER 6	3	3								

----- REMARKS -----+-----

(1) SELECTIVE PARTS: CERTAIN THE
CLASSIFICATION MARK, THEN PLACE
YOUR ORDER (REFER TO ILLUSTRATION)

14. FUEL INJECTION VALVE

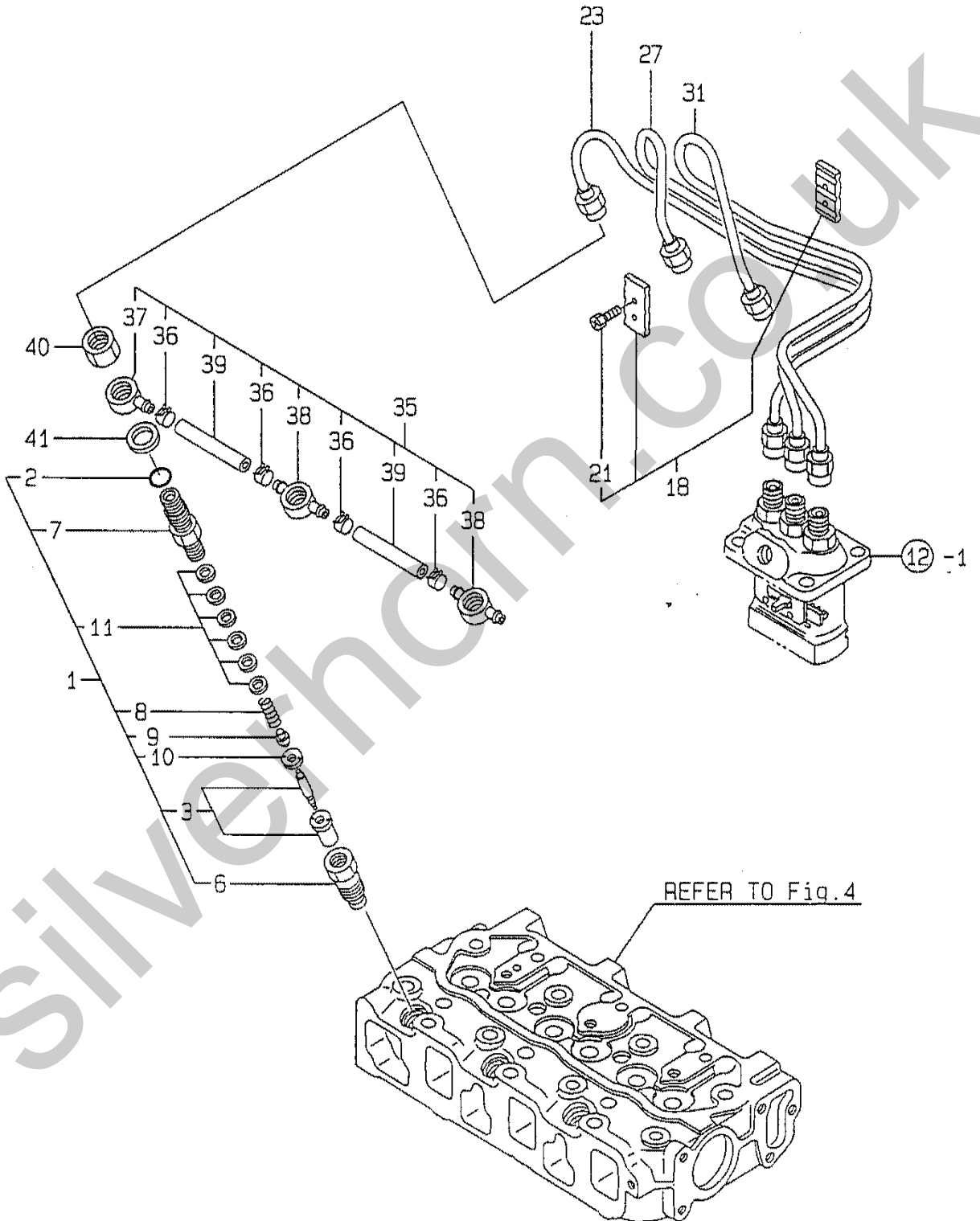

+-----+
 I 1C01 I
 I (1B01) I
 +-----+
 Y00R4520

(14) FUEL INJECTION VALVE

(A)=3TNE74-SA (D)=
 (B)=3TNE74-G2A (E)=
 (C)= (F)=

REF. NO.	LEV. 0	PART NO.	DESCRIPTION	-----Q'TY-----						I P/U A R
				(A)	(B)	(C)	(D)	(E)	(F)	
0 1	.	719620-53700	VALVE ASSY, F.INJECT	3	3					
2	..	129155-51580	O-RING	3	3					(G)
3	..	119620-53000	NOZZLE ASSY, F.INJECT	3	3					
6	..	119620-53080	NUT, VALVE W/CASE	3	3					
7	..	119620-53100	HOLDER, VALVE W/CASE	3	3					
8	..	119620-53120	SPRING, VALVE	3	3					
9	..	114250-53130	SEAT, NOZZLE SPRING	3	3					
10	..	119620-53140	SPACER, VALVE STOP	3	3					
11	..	114250-53400	SHIM PACK	3	3					
18	.	129150-59120	RETAINER, INJ. PIPE	1	1					
21	..	129150-59131	BOLT M4X14, HEX.SCKT.	2	2					
23	.	119620-59811	PIPE (1), FUEL INJECT	1	1					
27	.	119620-59821	PIPE (2), FUEL INJECT	1	1					
31	.	119620-59831	PIPE (3), FUEL INJECT	1	1					
35	.	119620-59540	PIPE ASSY, FUEL OVER	1	1					
36	..	124066-59100	CLAMP 8	4	4					
37	..	119260-59520	JOINT (B)	1	1					
38	..	119260-59530	JOINT (A)	2	2					
39	..	105025-59550	PIPE, FUEL RETURN	2	2					
40	.	119620-59700	NUT	3	3					
41	.	23414-140000	GASKET 14, ROUND	3	3					(G)

----- REMARKS -----

(G) THESE PARTS ARE SOLD BY FIG.20,
 1 REF.NO.1,2.

15.FUEL FILTER

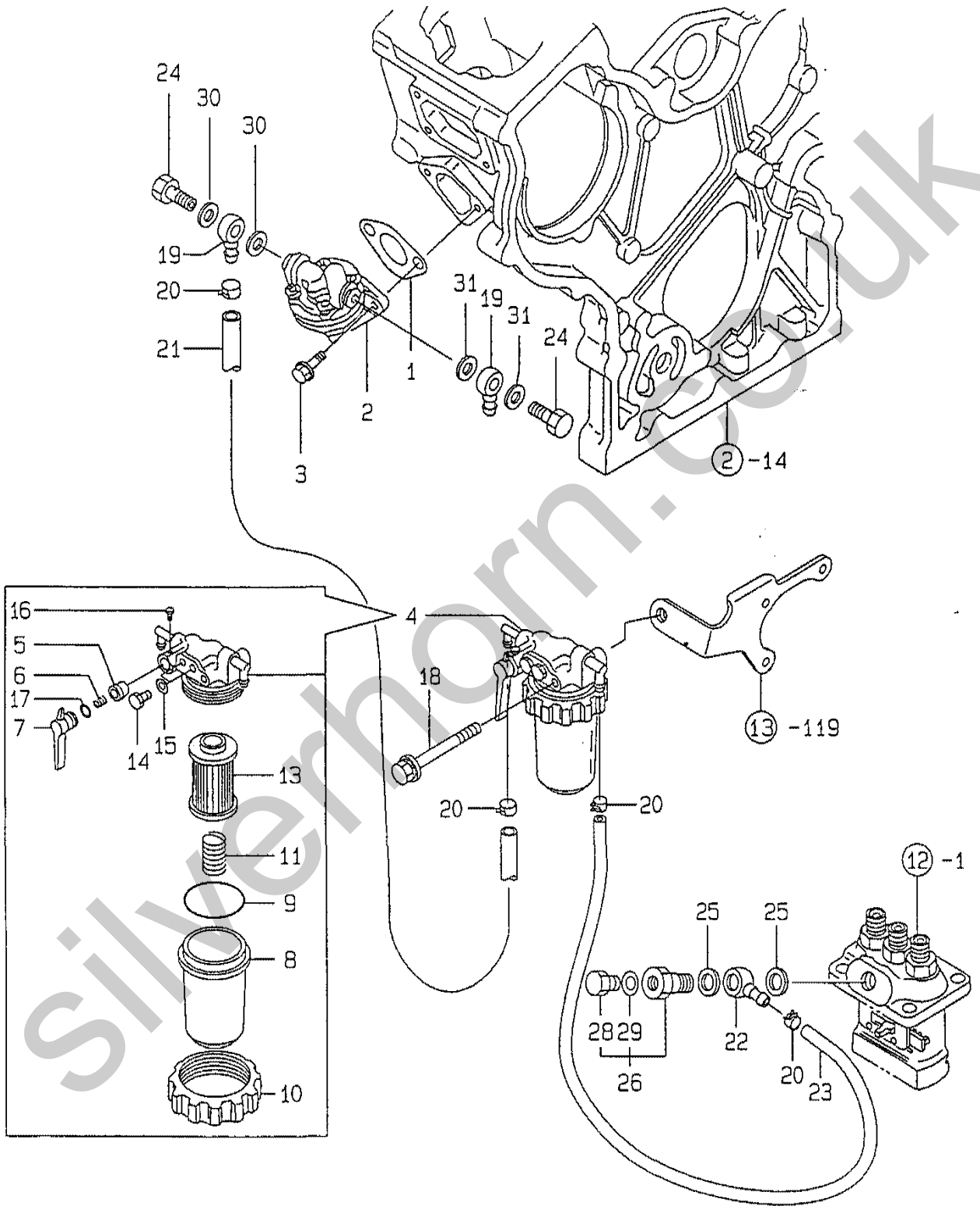

+-----+
 I 1C02 I
 I (1B01) I
 +-----+
 Y00R4520

(15) FUEL FILTER

(A)=3TNE74-SA (D)=
 (B)=3TNE74-G2A (E)=
 (C)= (F)=

REF. NO.	LEV. 0	PART NO.	DESCRIPTION	-----Q'TY-----						I P/U A R
				(A)	(B)	(C)	(D)	(E)	(F)	
1	.	121520-01851	GASKET, (NON-ASB.)	1	1					(G)
2	.	119600-52021	PUMP ASSY, FUEL FEED	1	1					
3	.	26106-060162	BOLT M 6X 16 PLATED	2	2					
4	.	171059-55600	STRAINER ASSY, FUEL	1	1					
5	..	104200-55321	VALVE, TAPER	1	1					
6	..	104200-55330	SPRING, TAPER VALVE	1	1					
7	..	104200-55341	HANDLE, COCK	1	1					
8	..	121254-55510	CUP, STRAINER	1	1					
9	..	102103-55520	O-RING	1	1					
10	..	110250-55610	RING, RETAINING	1	1					
11	..	121250-55620	SPRING	1	1					
13	..	124550-55700	ELEMENT, FUEL	1	1					
14	..	101720-55750	PLUG 6	2	2					
15	..	23418-060000	GASKET 6, NYLON	2	2					
16	..	104200-55750	SCREW M 4	1	1					
17	..	24311-240100	O-RING 1A P-10A	1	1					
18	.	26014-080702	BOLT W/WASHER M8X 70	1	1					
19	.	104264-59030	JOINT 8, PIPE	2	2					
20	.	124766-59050	CLAMP 12	4	4					
21	.	121236-59080	PIPE, FUEL (D12XL400)	1	1					
22	.	101304-59020	JOINT 12, PIPE	1	1					
23	.	124160-59080	PIPE	1	1					
24	.	105582-59150	BOLT, PIPE JOINT	2	2					
25	.	104200-59170	GASKET 12	2	2					(G)
26	.	103854-59191	BOLT W/PLUG & SEAL	1	1					
28	..	124060-59380	PLUG	1	1					
29	..	22190-060002	SEAL WASHER 6S	1	1					
30	.	22190-080002	SEAL WASHER 8S	2	2					(G)
31	.	22190-080002	SEAL WASHER 8S	2	2					(G)

REMARKS

(G) THESE PARTS ARE SOLD BY FIG.20,
 REF.NO.1,2.

16. ENGINE CONTROL DEVICE

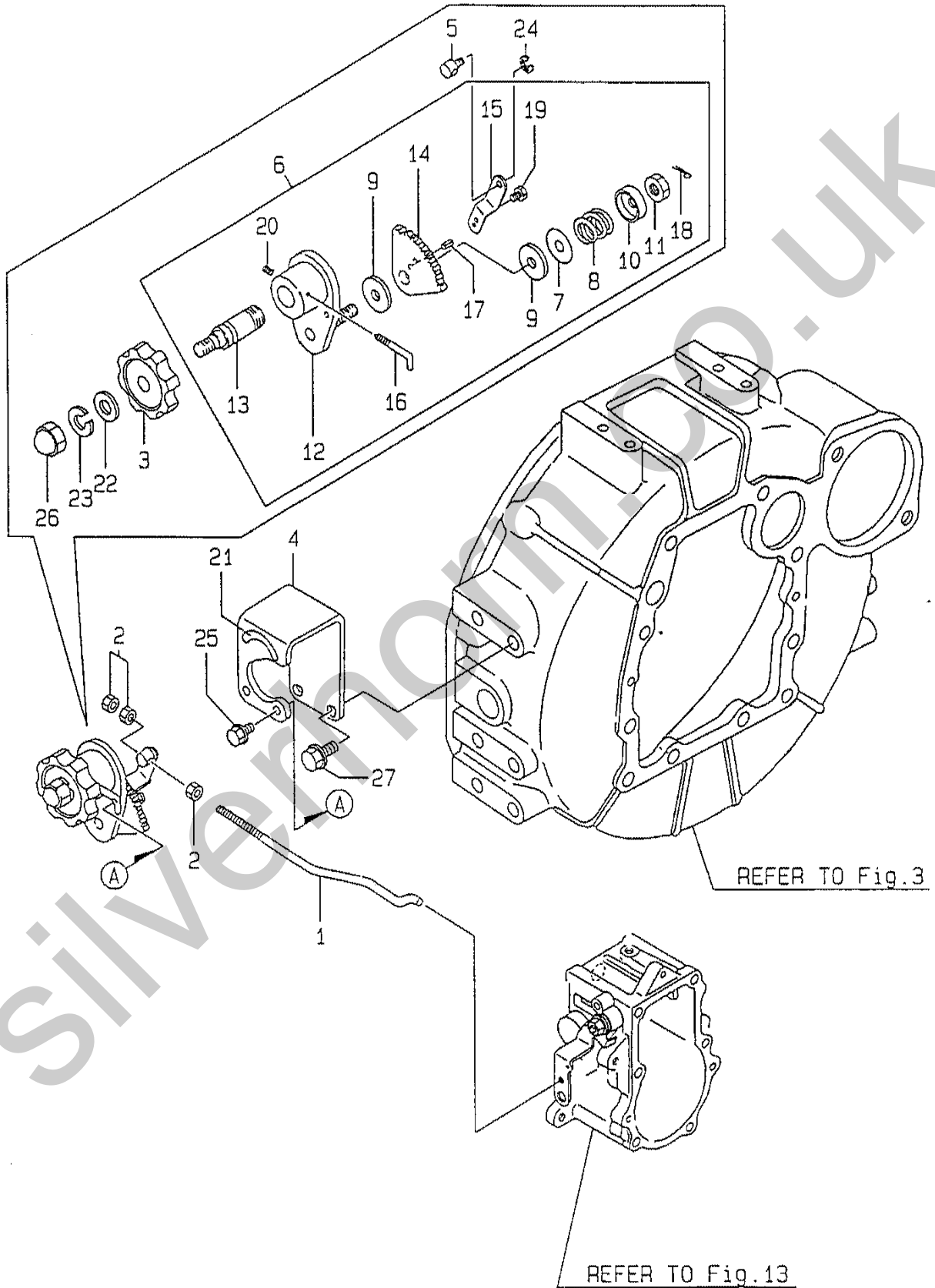

+-----+
I 1C03 I
I(1B01)I
+-----+
Y00R4520

(16) ENGINE CONTROL DEVICE

(A)=3TNE74-SA (D)=
(B)=3TNE74-G2A (E)=
(C)= (F)=

REF. NO.	LEV. 0	PART NO.	DESCRIPTION	-----Q'ITY-----						I P/U A R
				(A)	(B)	(C)	(D)	(E)	(F)	
1	.	119688-66120	LINK, ENGINE CONTROL	1	1					
2	.	26756-050002	LOCK NUT M 5 PLATED	3	3					
3	.	126650-66020	HANDLE, REGULATOR	1	1					
4	.	119888-66110	BRACKET	1	1					
5	.	119888-66130	PIVOT	1	1					
6	.	171048-67010	REGULATOR ASSY	1	1					
7	..	171102-66080	SPACER	1	1					
8	..	104200-66820	SPRING	1	1					
9	..	104200-66830	PLATE, FRICTION	2	2					
10	..	104200-66850	WASHER (B)	1	1					
11	..	104200-66860	NUT	1	1					
12	..	171085-67100	BRACKET, GEAR	1	1					
13	..	171085-67110	SHAFT, DRIVING	1	1					
14	..	171085-67120	GEAR	1	1					
15	..	171048-67130	LEVER	1	1					
16	..	171048-67140	STOPPER	1	1					
17	..	22351-020006	SPRING PIN 2X 6	1	1					
18	..	22411-200150	COTTER PIN 2.0X15	1	1					
19	..	26116-060082	BOLT M 6X 8 PLATED	1	1					
20	..	26921-050122	SCREW M 5X 12	1	1					
21	.	170064-67210	LABEL, HANDLE	1	1					
22	.	22117-100000	WASHER 10	1	1					
23	.	22217-100000	SPRING WASHER 10	1	1					
24	.	22272-000050	CIRCLIP E- 5	1	1					
25	.	26106-060102	BOLT M 6X 10 PLATED	2	2					
26	.	26657-100002	CAP NUT M10	1	1					
27	.	26106-080162	BOLT M 8X 16 PLATED	2	2					

17. STARTING MOTOR

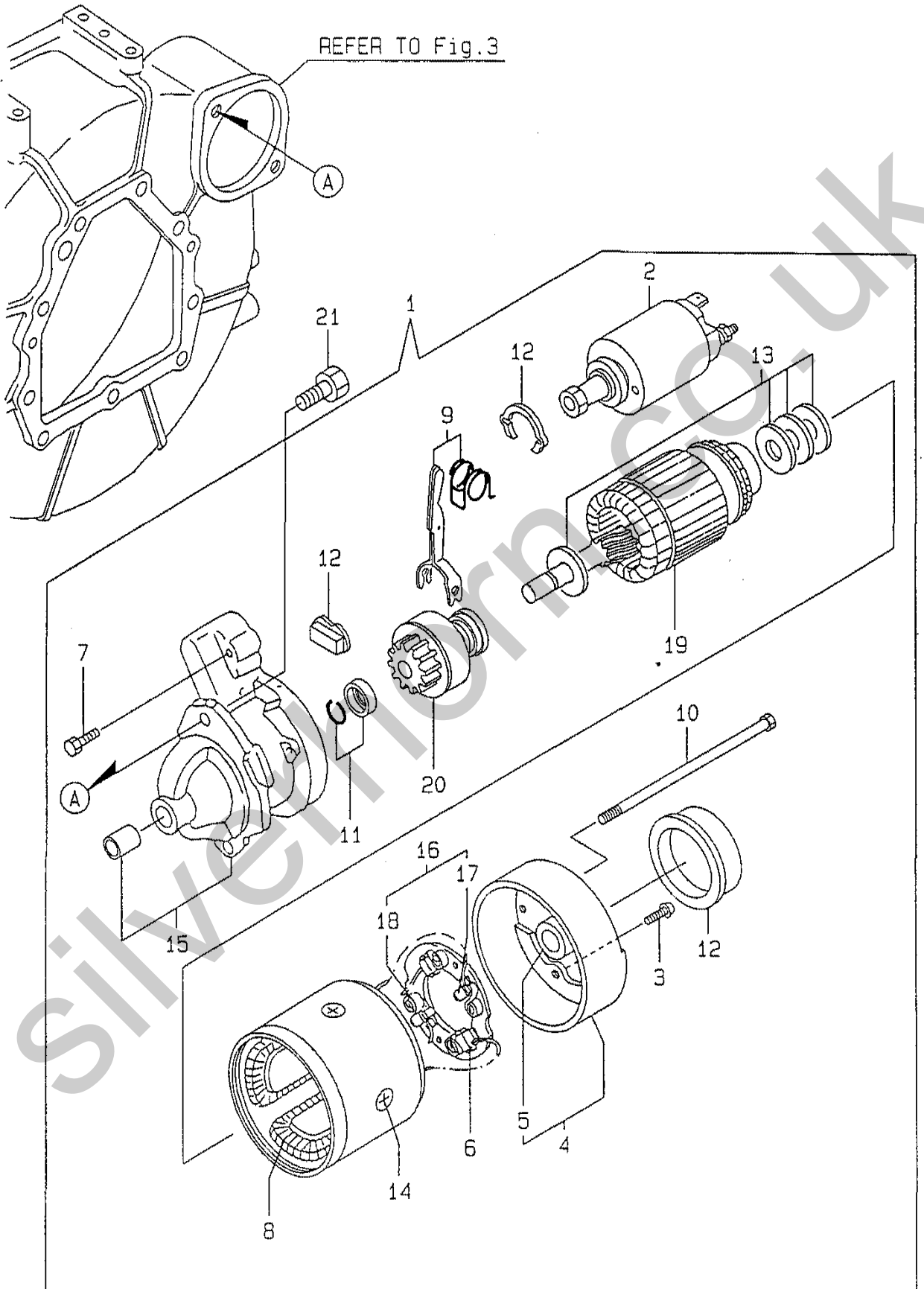

+-----+
 I 1C04 I
 I(1B01)I
 +-----+
 Y00R4520

(17) STARTING MOTOR

(A)=3TNE74-SA (D)=
 (B)=3TNE74-G2A (E)=
 (C)= (F)=

REF. NO.	LEV. 0	PART NO.	DESCRIPTION	-----Q'TY----- I P/U A R					
				(A)	(B)	(C)	(D)	(E)	(F)
1	.	119631-77010	STARTER	1	1				
2	..	X2114275070	SWITCH, MAGNETIC	1	1				
3	..	X2114283500	SCREW SET	1	1				
4	..	X2114430010	COVER ASSY, REAR	1	1				
5	...	X2114535200	METAL, STARTER	1	1				
6	..	X2114531200	BRUSH (+)	2	2				
7	..	X2114586700	BOLT M6X 37	2	2				
8	..	X2114631090	COIL ASSY, FIELD	1	1				
9	..	X2114660130	LEVER KIT, SHIFT	1	1				
10	..	X2114680050	BOLT, THROUGH	2	2				
11	..	X2114715500	STOPPER SET, PINION	1	1				
12	..	X2114780060	COVER ASSY, DUST	1	1				
13	..	X2114811000	WASHER KIT, THRUST	1	1				
14	..	X2114821500	SCREW SET	1	1				
15	..	X2114966130	CASE ASSY, GEAR	1	1				
16	..	X2114990010	HOLDER ASSY, BRUSH	1	1				
17	...	X2114831300	BRUSH (-)	1	1				
18	...	X2114931400	SPRING, BRUSH	3	3				
19	..	124190-77110	ARMATURE, (NON-ASB.)	1	1				
20	..	124190-77760	PINION ASSY	1	1				
21	.	26116-120252	BOLT M12X 25 PLATED	2	2				

18. GENERATOR

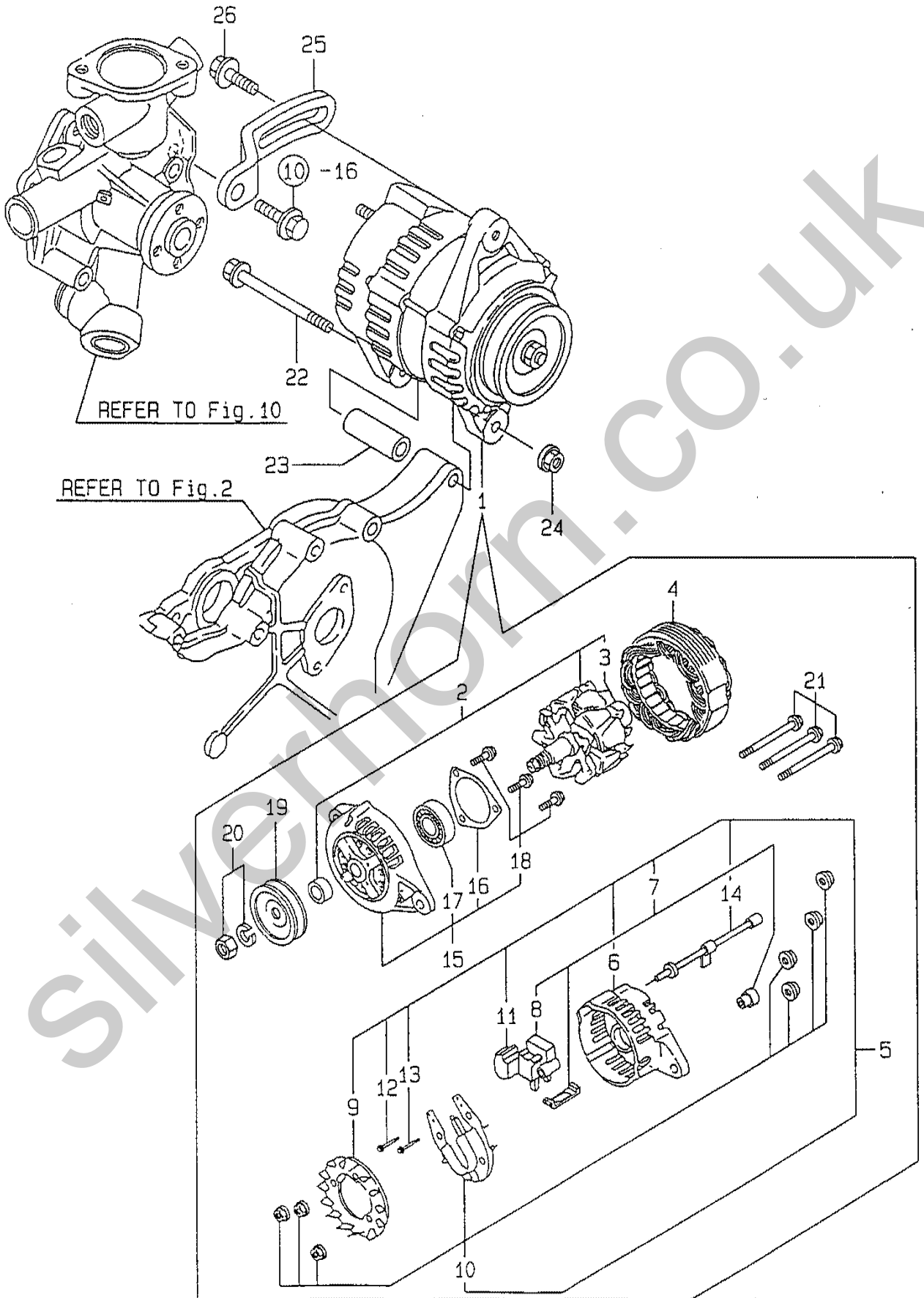

+-----+
 I 1C05 I
 I(1801)I
 +-----+
 Y00R4520

(18) GENERATOR

(A)=3TNE74-SA (D)=
 (B)=3TNE74-G2A (E)=
 (C)= (F)=

REF. NO.	LEV. 0	PART NO.	DESCRIPTION	-----Q'TY----- I P/U A R					
				(A)	(B)	(C)	(D)	(E)	(F)
1	.	119836-77200	GENERATOR	1	1				
2	..	119836-77700	ROTOR ASSY	1	1				
3	...	119836-77850	BALL BEARING	1	1				
4	..	119836-77710	STARTER ASSY	1	1				
5	..	119836-77721	COVER ASSY, REAR	1	1				
6	...	119836-77730	COVER, REAR	1	1				
7	...	119836-77741	BRUSH ASSY,REGULATOR	1	1				
8	119836-77750	BRUSH ASSY	1	1				
9	...	119836-77760	GUIDE, FAN SIDE	1	1				
10	...	119836-77770	DIODE ASSY	1	1				
11	...	119836-77780	CONDENSER	1	1				
12	...	119836-77871	BOLT (1)	1	1				
13	...	119836-77880	BOLT (2)	1	1				
14	...	119836-77890	WIRE ASSY, LEAD	1	1				
15	..	119836-77790	COVER ASSY, FRONT	1	1				
16	...	119836-77800	RETAINER, BEARING	1	1				
17	...	119836-77840	BALL BEARING	1	1				
18	...	119836-77860	SCREW KID	1	1				
19	..	119836-77810	PULLEY	1	1				
20	..	119836-77820	NUT ASSY, PULLEY	1	1				
21	..	119836-77830	BOLT, THROUGH	1	1				
22	.	26106-081052	BOLT M 8X105 PLATED	1	1				
23	.	119621-77340	SPACER	1	1				
24	.	26366-080002	NUT M 8	1	1				
25	.	119621-77331	ADJUSTER, BELT	1	1				
26	.	26106-080182	BOLT M 8X 18 PLATED	1	1				

19. PANEL

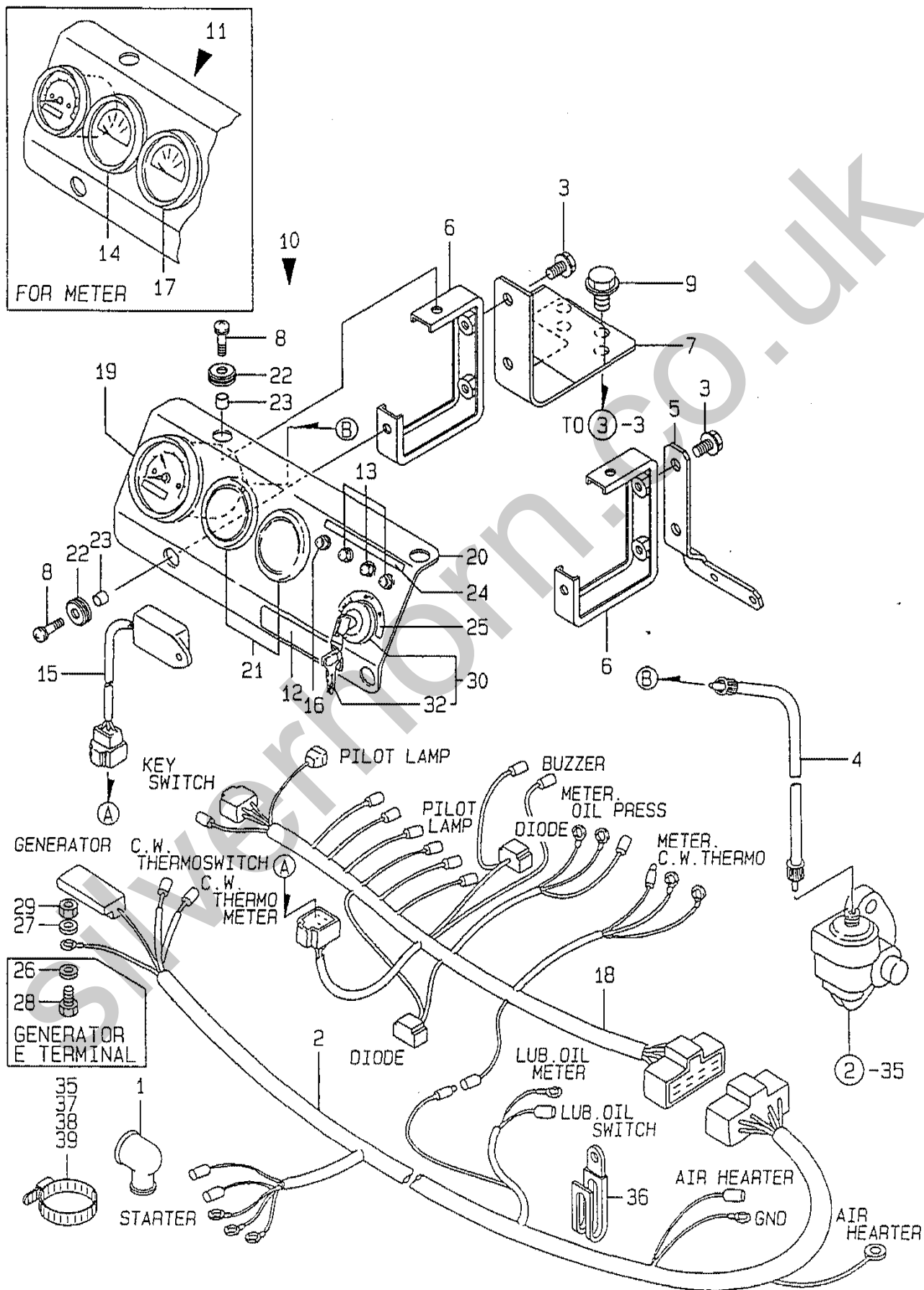

+-----+
 I 1CD6 I
 I(1B01)I
 +-----+
 Y00R4520

(19) PANEL

(A)=3TNE74-SA (D)=
 (B)=3TNE74-G2A (E)=
 (C)= (F)=

REF. NO.	LEV. 0	PART NO.	DESCRIPTION	-----Q'TY-----						I P/U A R
				(A)	(B)	(C)	(D)	(E)	(F)	
1	.	124550-77030	COVER, TERMINAL	1	1					
2	.	119888-91021	HARNESS (A), WIRE	1	1					
3	.	26106-080122	BOLT M 8X 12 PLATED	4	4					
4	.	124701-91140	CABLE L= 985	1	1					
5	.	119288-91140	SUPPORT	1	1					
6	.	119888-91120	SUPPORT, PANEL	2	2					
7	.	119288-91130	BRACKET	1	1					
8	.	26033-060202	SCREW M 6X 20	4	4					
9	.	26106-100502	BOLT M10X 50 PLATED	2	2					
10	.	119888-91101	PANEL ASSY, INSTRUM	1	1					
11	.	119888-91201	PANEL ASSY, INSTRUM	1	1					(1)
12	..	104507-07190	LABEL, YANMAR	1	1					
13	..	124732-77720	LAMP, CHARGING	3	3					
14	..	171010-77850	THERMOMETER, C.W.	1	1					
15	..	128300-77920	TIMER	1	1					
16	..	124559-77971	LAMP, PILOT	1	1					
17	..	171090-91010	GAUGE, PRESSURE	1	1					
18	..	119888-91031	HARNESS (B), WIRE	1	1					
19	..	171080-91100	TACHOMETER	1	1					
20	..	119888-91110	BODY, CONT. PANEL	1	1					
21	..	124770-91220	COVER 52	2	2					
22	..	121400-91520	ABSORBER	4	4					
23	..	121400-91530	SPACER	4	4					
24	..	119888-91610	LABEL, CW & OIL LAMP	1	1					
25	..	119888-91620	LABEL, KEY SWITCH	1	1					
26	..	22117-050000	WASHER 5	1	1					
27	..	22117-050000	WASHER 5	1	1					
28	..	26116-050102	BOLT M 5X 10 PLATED	1	1					
29	..	26716-050002	NUT M 5	1	1					
30	..	933110-00100	SWITCH ASSY, STARTER	1	1					
32	...	933110-00301	KEY ASSY	1	1					
35	.	121750-59890	RETAINER	1	1					
36	.	194180-51640	CLAMP, WIRE HARNESS	1	1					
37	.	121750-59890	RETAINER		1					
38	.	121750-59890	RETAINER	1						
39	.	121750-59890	RETAINER	1						

REMARKS

(1) WITH C.W.THERMOMETER(REF.NO.14,
 I P/# 171010-77850) & PRESSURE
 I GAUGE(REF.NO.17,P/# 171090-91010).

Y100151

20. GASKET SET

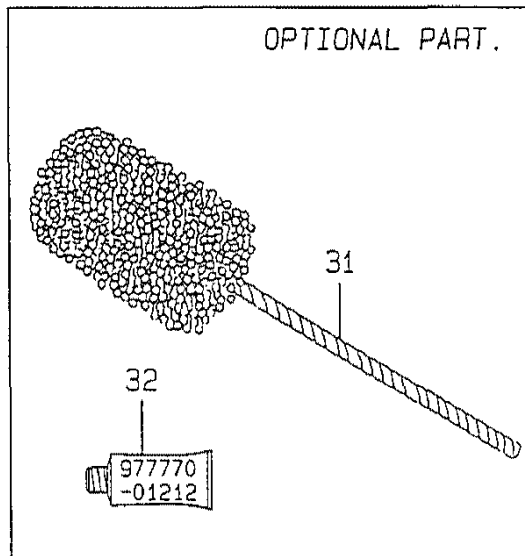
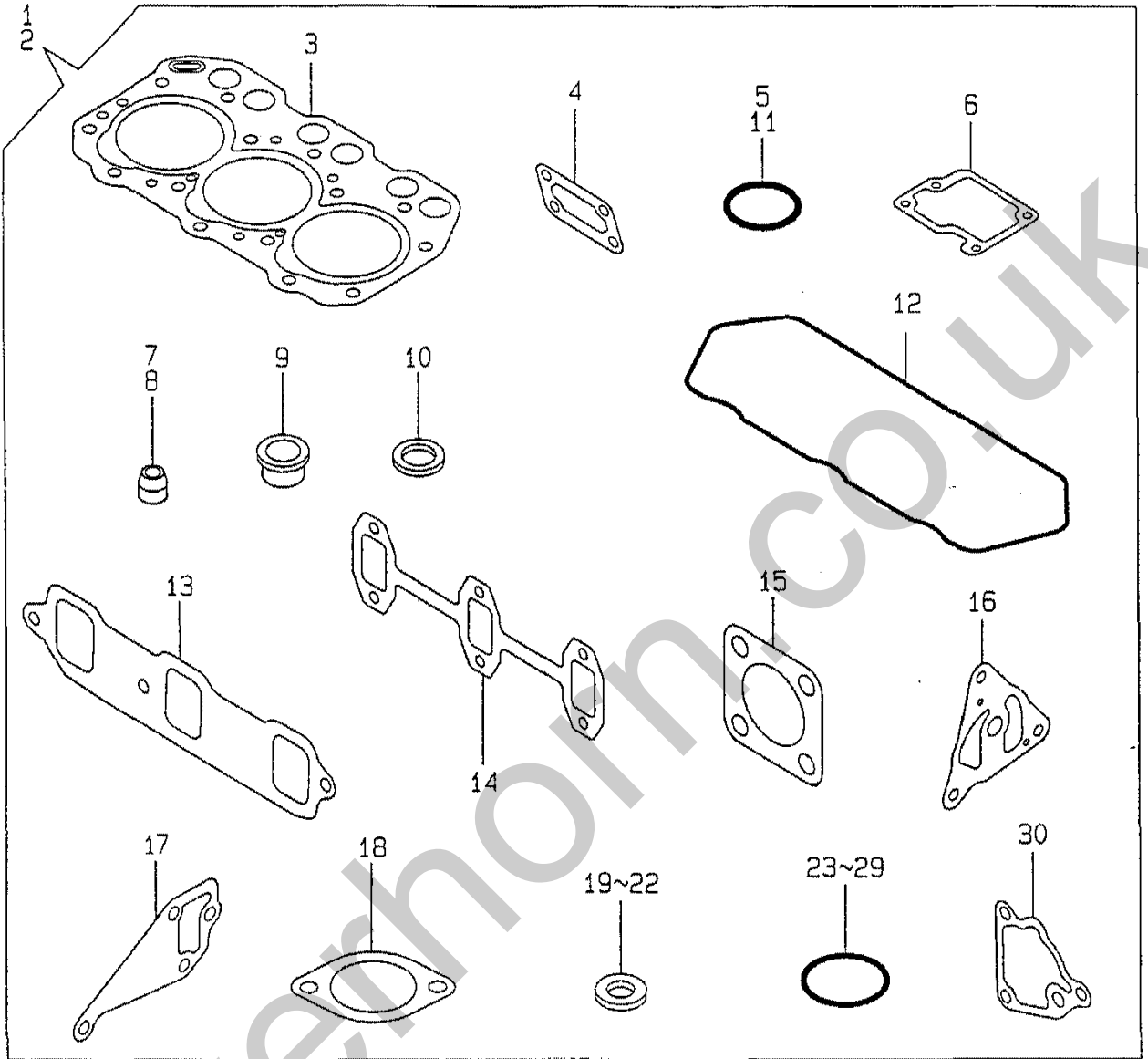

+-----+
 I 1007 I
 I(1B01)I
 +-----+
 Y00R4520

(20) GASKET SET

(A)=3TNE74-SA (D)=
 (B)=3TNE74-G2A (E)=
 (C)= (F)=

REF. NO.	LEV. 0	PART NO.	DESCRIPTION	-----Q'TY-----						I P/U A R
				(A)	(B)	(C)	(D)	(E)	(F)	
1	.	719623-92610	GASKET SET(NON-ASB.)	1						(1)
2	.	719623-92620	GASKET SET(NON-ASB.)		1					(1)
3	..	119623-01330	GASKET, CYL. HEAD	1	1					
4	..	119660-01562	GASKET, (NON-ASB.)	1	1					
5	..	24311-000320	O-RING 1A P-32.0	1	1					
6	..	119620-03031	GASKET, (NON-ASB.)	1	1					
7	..	124950-11340	SEAL, VALVE STEM	3	3					
8	..	124160-11340	SEAL, VALVE STEM	3	3					
9	..	119600-11450	PROTECTOR, NOZZLE	3	3					
10	..	119600-11460	GASKET, NOZZLE	6	6					
11	..	24311-000320	O-RING 1A P-32.0	1	1					
12	..	119620-11310	GASKET, BONNET	1	1					
13	..	119660-12111	GASKET, SUC.MANIFOLD	1	1					
14	..	119620-13110	GASKET, EXH.MANIFOLD	1	1					
15	..	121000-13201	GASKET, SILENCER	2	2					
16	..	119660-32020	GASKET, L.O.PUMP	1	1					
17	..	119620-42020	GASKET, C.W. PUMP	1	1					
18	..	129350-49541	GASKET, (NON-ASB.)	1	1					
19	..	124465-44950	GASKET 16	2	2					
20	..	104200-59170	GASKET 12	2	2					
21	..	23414-140000	GASKET 14, ROUND	3	3					
22	..	22190-080002	SEAL WASHER 8S	4	4					
23	..	24311-000120	O-RING 1A P 12.0	4	4					
24	..	129155-51580	O-RING	3	3					
25	..	24341-000240	O-RING 1A S-24.0	1	1					
26	..	24311-000160	O-RING 1A P-16.0	1	1					
27	..	24311-000120	O-RING 1A P 12.0	1	1					
28	..	24321-000600	O-RING 1A G-60.0		1					
29	..	24321-000700	O-RING 1A G-70.0		1					
30	..	119660-35113	GASKET, (NON-ASB.)	1	1					
31	.	129400-92410	FLEX HORN	1	1					(1)
32	.	977770-01212	GASKET, LIQUID	1	1					(1)

REMARKS

I(1) OPTIONAL PART.

PART NO.	DESCRIPTION	CATALOG NO.	GRP. NO.	REF. NO.	LOC. NO.	PART NO.	DESCRIPTION	CATALOG NO.	GRP. NO.	REF. NO.	LOC. NO.
X2114275070	SWITCH, MAGNETIC	YOOR4520	17	2	1C04	119285-66080	SHAFT ASSY,REGULATOR	YOOR4520	13	56	1B15
X2114283500	SCREW SET	YOOR4520	17	3	1C04	119288-08100	BRACKET (A), ENGINE	YOOR4520	11	1	1B13
X2114430010	COVER ASSY, REAR	YOOR4520	17	4	1C04	119288-55900	BRACKET, FUEL FILTER	YOOR4520	13	119	1B16
X2114531200	BRUSH (+)	YOOR4520	17	6	1C04	119288-61200	CASE ASSY, GOVERNOR	YOOR4520	13	15	1B15
X2114535200	METAL, STARTER	YOOR4520	17	5	1C04	119288-61510	LEVER ASSY, GOVERNOR	YOOR4520	13	30	1B15
X2114586700	BOLT M6X 37	YOOR4520	17	7	1C04	119288-91130	BRACKET	YOOR4520	19	7	1C06
X2114631090	COIL ASSY, FIELD	YOOR4520	17	8	1C04	119288-91140	SUPPORT	YOOR4520	19	5	1C06
X2114660130	LEVER KIT, SHIFT	YOOR4520	17	9	1C04	119305-35150	FILTER, LUB. OIL	YOOR4520	9	18	1B11
X2114680050	BOLT, THROUGH	YOOR4520	17	10	1C04	119358-13640	RAINCAP,HUFFLER	YOOR4520	6	16	1B08
X2114715500	STOPPER SET, PINION	YOOR4520	17	11	1C04	119600-01050	PLUG PT174	YOOR4520	1	5	1B02
X2114780060	COVER ASSY, DUST	YOOR4520	17	12	1C04	119600-01600	HOUSING, FLYWHEEL	YOOR4520	3	3	1B04
X2114811000	WASHER KIT, THRUST	YOOR4520	17	13	1C04	119600-01722	SPACER, OIL SUMP	YOOR4520	3	14	1B04
X2114821500	SCREW SET	YOOR4520	17	14	1C04	119600-01770	SUMP ASSY, LUB. OIL	YOOR4520	3	20	1B04
X2114831300	BRUSH (-)	YOOR4520	17	17	1C04	119600-11450	PROTECTOR, NOZZLE	YOOR4520	4	30	1B05
X2114931400	SPRING, BRUSH	YOOR4520	17	18	1C04				20	9	1C07
X2114966130	CASE ASSY, GEAR	YOOR4520	17	15	1C04	119600-11460	GASKET, NOZZLE	YOOR4520	4	29	1B05
X2114990010	HOLDER ASSY, BRUSH	YOOR4520	17	16	1C04				20	10	1C07
101304-59020	JOINT 12, PIPE	YOOR4520	15	22	1C02	119600-21580	FLYWHEEL ASSY	YOOR4520	8	16	1B10
101720-55750	PLUG 6	YOOR4520	15	14	1C02	119600-34800	DIPSTICK, LUB. OIL	YOOR4520	9	14	1B11
102103-55520	O-RING	YOOR4520	15	9	1C02	119600-34820	DIPSTICK, LUB. OIL	YOOR4520	9	15	1B11
103854-59191	BOLT W/PLUG & SEAL	YOOR4520	15	26	1C02	119600-35081	PIPE ASSY, LUB.OIL	YOOR4520	9	30	1B11
104200-55321	VALVE, TAPER	YOOR4520	15	5	1C02	119600-35091	PIPE ASSY,OIL INTAKE	YOOR4520	9	31	1B11
104200-55330	SPRING, TAPER VALVE	YOOR4520	15	6	1C02	119600-52021	PUMP ASSY, FUEL FEED	YOOR4520	15	2	1C02
104200-55341	HANDLE, COCK	YOOR4520	15	7	1C02	119600-61100	DRIVING SET, GOV.	YOOR4520	13	4	1B15
104200-55750	SCREW M 4	YOOR4520	15	16	1C02	119600-61200	WEIGHT ASSY, GOV.	YOOR4520	13	5	1B15
104200-59170	GASKET 12	YOOR4520	15	25	1C02	119600-61541	SHIFTER,P.T.O.	YOOR4520	13	46	1B15
			20	20	1C07	119600-61650	SPRING, STARTING	YOOR4520	13	50	1B15
104200-66820	SPRING	YOOR4520	16	8	1C03	119600-61900	RETAINER, SHAFT	YOOR4520	13	54	1B15
104200-66830	PLATE, FRICTION	YOOR4520	16	9	1C03	119600-66020	SPRING, REGULATOR	YOOR4520	13	64	1B15
104200-66850	WASHER (B)	YOOR4520	16	10	1C03	119600-66530	TORQUE SPRING ASSY	YOOR4520	13	73	1B15
104200-66860	NUT	YOOR4520	16	11	1C03	119600-66700	UNGLEICH ASSY	YOOR4520	13	81	1B15
104211-11370	CAP, VALVE	YOOR4520	4	27	1B05	119600-66840	NUT, CAP	YOOR4520	13	108	1B15
104264-59030	JOINT 8, PIPE	YOOR4520	15	19	1C02	119610-01490	HOUSING ASSY, GEAR	YOOR4520	2	14	1B03
104507-07190	LABEL, YANMAR	YOOR4520	19	12	1C06	119610-01590	COVER ASSY, HOUSING	YOOR4520	2	1	1B03
105010-11230	SCREW, VALVE	YOOR4520	4	38	1B05	119620-01200	BOLT, CYLINDER HEAD	YOOR4520	1	23	1B02
			42	1B05	119620-01620	PARALLEL PIN 6X10	YOOR4520	3	9	1B04	
105025-59550	PIPE, FUEL RETURN	YOOR4520	14	39	1C01	119620-01750	CAP, FLYWHEEL COVER	YOOR4520	3	7	1B04
105225-23200	BOLT, ROD	YOOR4520	8	39	1B10	119620-01800	SEAL HTC456208, OIL	YOOR4520	2	4	1B03
105546-51330	SPRING, DELIV. VALVE	YOOR4520	12	25	1B14	119620-02020	BOLT	YOOR4520	1	6	1B02
105582-59150	BOLT, PIPE JOINT	YOOR4520	15	24	1C02	119620-02410	BUSH, CAMSHAFT	YOOR4520	1	21	1B02
110250-55610	RING, RETAINING	YOOR4520	15	10	1C02	119620-02450	BEARING, THRUST	YOOR4520	7	4	1B09
114250-53130	SEAT, NOZZLE SPRING	YOOR4520	14	9	1C01	119620-03020	PLATE, SHELTER	YOOR4520	4	51	1B05
114250-53400	SHIM PACK	YOOR4520	14	11	1C01	119620-03031	GASKET, (NON-ASB.)	YOOR4520	4	52	1B05
114350-22301	PIN, PISTON D=21	YOOR4520	8	32	1B10				20	6	1C07
119232-61510	LEVER ASSY, GOVERNOR	YOOR4520	13	29	1B15	119620-11090	SEAT, EXHAUST VALVE	YOOR4520	4	19	1B05
119232-61540	SPRING, LEVER	YOOR4520	13	45	1B15	119620-11110	VALVE, EXHAUST	YOOR4520	4	21	1B05
119259-44570	CAP, RADIATOR	YOOR4520	11	5	1B13	119620-11120	SPRING, VALVE	YOOR4520	4	22	1B05
119260-07900	LIFTER, ENGINE	YOOR4520	4	2	1B05	119620-11180	RETAINER, SPRING	YOOR4520	4	23	1B05
119260-59520	JOINT (B)	YOOR4520	14	37	1C01	119620-11200	SUPPORT ASSY, ARM	YOOR4520	4	31	1B05
119260-59530	JOINT (A)	YOOR4520	14	38	1C01	119620-11240	SHAFT ASSY, ROCKER	YOOR4520	4	32	1B05
119260-66720	ANGLEICH ASSY	YOOR4520	13	80	1B15	119620-11260	SUPPORT, ROCKER ARM	YOOR4520	4	35	1B05
119265-44400	JOIN, PIPE M16	YOOR4520	9	41	1B11	119620-11280	SPRING	YOOR4520	4	36	1B05
119280-01600	FLANGE, MOUNTING	YOOR4520	3	2	1B04	119620-11310	GASKET, BONNET	YOOR4520	4	55	1B05
119280-49020	PIPE (B), C. WATER	YOOR4520	11	32	1B13				20	12	1C07

PART NO.	DESCRIPTION	CATALOG NO.	GRP. NO.	REF. NO.	LOG NO.	PART NO.	DESCRIPTION	CATALOG NO.	GRP. NO.	REF. NO.	LOG NO.
119620-11330	BONNET ASSY, (NON-ASB)	Y00R4520	4	50	1805	119621-66051	LEVER, REGULATOR	Y00R4520	13	65	1815
119620-11350	STUD	Y00R4520	4	47	1805	119621-77331	ADJUSTER, BELT	Y00R4520	18	25	1C05
119620-11390	JOINT	Y00R4520	4	56	1805	119621-77340	SPACER	Y00R4520	18	23	1C05
119620-11801	GUIDE, VALVE	Y00R4520	4	12	1805	119623-01330	GASKET, CYL. HEAD	Y00R4520	1	24	1802
119620-13110	GASKET, EXH.MANIFOLD	Y00R4520	6	2	1808				20	3	1C07
			20	14	1C07	119623-01950	SHIM PACK	Y00R4520	2	23	1803
119620-13501	SILENCER	Y00R4520	6	11	1808	119623-11080	SEAT, SUCTION VALVE	Y00R4520	4	18	1805
119620-13510	MUFFLER BODY ASSY	Y00R4520	6	12	1808	119623-11100	VALVE, INTAKE	Y00R4520	4	20	1805
119620-13520	TAILPIPE ASSY	Y00R4520	6	13	1808	119623-21700	CRANKSHAFT ASSY	Y00R4520	8	1	1810
119620-13560	TAILPIPE	Y00R4520	6	14	1808	119623-22080	PISTON W/RING	Y00R4520	8	24	1810
119620-14100	GEAR, CAMSHAFT	Y00R4520	7	7	1809	119623-22500	RING SET PISTON	Y00R4520	8	26	1810
119620-14200	TAPPET	Y00R4520	7	1	1809	119623-22900	PISTON W/RING OS=.25	Y00R4520	8	42	1810
119620-14401	ROD, PUSH	Y00R4520	7	2	1809	119623-22950	RING SET OS=0.25	Y00R4520	8	44	1810
119620-21500	BOLT, FLYWHEEL	Y00R4520	8	55	1810	119629-14580	CAMSHAFT ASSY	Y00R4520	7	3	1809
119620-21591	FLYWHEEL W/RING GEAR	Y00R4520	8	20	1810	119629-66510	TORQUE SPRING ASSY	Y00R4520	13	72	1815
119620-21941	WASHER	Y00R4520	8	10	1810	119631-13101	MANIFOLD, EXHAUST	Y00R4520	6	1	1808
119620-23910	BUSH, PISTON PIN	Y00R4520	8	37	1810	119631-77010	STARTER	Y00R4520	17	1	1C04
119620-25102	GEAR W/BUSH, IDLE	Y00R4520	7	11	1809	119632-61200	CASE ASSY, GOVERNOR	Y00R4520	13	14	1815
119620-25912	BUSH	Y00R4520	7	13	1809	119640-01640	DRAIN PLUG H22	Y00R4520	3	17	1804
119620-42020	GASKET, C.W. PUMP	Y00R4520	10	15	1812	119642-33030	COOLER, OIL	Y00R4520	9	39	1811
			20	17	1C07	119642-33100	BRACKET	Y00R4520	9	40	1811
119620-42320	O-RING	Y00R4520	10	12	1812	119642-42000	PUMP ASSY, COOL. WATE	Y00R4520	10	2	1812
119620-51101	PLUNGER W/BARREL	Y00R4520	12	4	1814	119642-49030	PIPE	Y00R4520	9	43	1811
119620-51170	RETAINER	Y00R4520	12	7	1814	119644-21200	CRANKGEAR	Y00R4520	8	5	1810
119620-51180	RETAINER	Y00R4520	12	8	1814	119645-49020	PIPE (B), C. WATER	Y00R4520	11	31	1813
119620-51190	SPRING, PLUNGER	Y00R4520	12	9	1814	119650-42291	V-BELT FN=35.0	Y00R4520	10	17	1812
119620-51250	SHIM PACK	Y00R4520	12	10	1814	119653-12500	CLEANER ASSY, AIR	Y00R4520	5	5	1807
119620-51300	VALVE W/SEAT, DELIV.	Y00R4520	12	22	1814	119653-12550	PIPE, AIR INTAKE	Y00R4520	5	10	1807
119620-51340	HOLDER, DELIV. VALVE	Y00R4520	12	26	1814	119653-12600	SUPPORT, AIR CLEANER	Y00R4520	5	11	1807
119620-51350	GASKET, DELIVERY	Y00R4520	12	27	1814	119653-66500	ENGINE STOP DEVICE	Y00R4520	13	67	1815
119620-51370	O-RING	Y00R4520	12	28	1814	119655-12560	ELEMENT	Y00R4520	5	7	1807
119620-51450	GUIDE, PLUNGER	Y00R4520	12	29	1814	119660-01510	PLUG 10X14	Y00R4520	2	17	1803
119620-51461	PIN	Y00R4520	12	30	1814	119660-01551	COVER	Y00R4520	2	20	1803
119620-51510	PINION	Y00R4520	12	32	1814	119660-01562	GASKET, (NON-ASB.)	Y00R4520	2	21	1803
119620-51650	PLATE	Y00R4520	12	34	1814				20	4	1C07
119620-51660	SCREW	Y00R4520	12	35	1814	119660-01570	STUD M6X12	Y00R4520	2	22	1803
119620-51670	PIN	Y00R4520	12	36	1814	119660-01640	CASE ASSY, OIL SEAL	Y00R4520	3	10	1804
119620-51680	PIN	Y00R4520	12	37	1814	119660-01821	BEARING, FUEL CAM.	Y00R4520	7	17	1809
119620-51700	TAPPET ASSY	Y00R4520	12	38	1814	119660-01911	PIPE, KNOCK	Y00R4520	2	5	1803
119620-53000	NOZZLE ASSY, F. INJECT	Y00R4520	14	3	1C01	119660-12101	MANIFOLD, AIR INTAKE	Y00R4520	5	1	1807
119620-53080	NUT, VALVE W/CASE	Y00R4520	14	6	1C01	119660-12111	GASKET, SUC.MANIFOLD	Y00R4520	5	2	1807
119620-53100	HOLDER, VALVE W/CASE	Y00R4520	14	7	1C01				20	13	1C07
119620-53120	SPRING, VALVE	Y00R4520	14	8	1C01	119660-21651	V-PULLEY	Y00R4520	8	8	1810
119620-53140	SPACER, VALVE STOP	Y00R4520	14	10	1C01	119660-25022	RETAINER, IDLE GEAR	Y00R4520	7	9	1809
119620-59540	PIPE ASSY, FUEL OVER	Y00R4520	14	35	1C01	119660-25052	SHAFT, IDLE GEAR	Y00R4520	7	10	1809
119620-59700	NUT	Y00R4520	14	40	1C01	119660-32001	PUMP ASSY, LUB. OIL	Y00R4520	9	1	1811
119620-59811	PIPE (1), FUEL INJECT	Y00R4520	14	23	1C01	119660-32020	GASKET, L.O.PUMP	Y00R4520	9	11	1811
119620-59821	PIPE (2), FUEL INJECT	Y00R4520	14	27	1C01				20	16	1C07
119620-59831	PIPE (3), FUEL INJECT	Y00R4520	14	31	1C01	119660-35102	BRACKET, OIL FILTER	Y00R4520	9	16	1811
119620-77820	CONNECTOR, GLOW PLUG	Y00R4520	4	64	1805	119660-35113	GASKET, (NON-ASB.)	Y00R4520	9	17	1811
119621-01611	REAR PLATE	Y00R4520	3	4	1804				20	30	1C07
119621-21680	BOLT M12X1.25, FLANGE	Y00R4520	8	9	1810	119660-35300	VALVE ASSY, OIL PRESS	Y00R4520	9	19	1811
119621-44500	RADIATOR	Y00R4520	11	4	1813	119660-42004	PUMP ASSY, CW (NON-ASB)	Y00R4520	10	1	1812
119621-44560	FAN-GUARD	Y00R4520	11	6	1813	119660-42350	V-PULLEY, C.W. PUMP	Y00R4520	10	18	1812

PART NO.	DESCRIPTION	CATALOG NO.	GRP. NO.	REF. NO.	LOC NO.	PART NO.	DESCRIPTION	CATALOG NO.	GRP. NO.	REF. NO.	LOC. NO.	
119660-51500	RACK	Y00R4520	12	31	1814	119888-91101	PANEL ASSY, INSTRUM	Y00R4520	19	10	1C06	
119660-51530	RETAINER, RACK	Y00R4520	12	33	1814	119888-91110	BODY, CONT. PANEL	Y00R4520	19	20	1C06	
119660-61052	GASKET, (NON-ASB.)	Y00R4520	13	19	1815	119888-91120	SUPPORT, PANEL	Y00R4520	19	6	1C06	
119660-61060	COVER, GOVERNOR CASE	Y00R4520	13	2	1815	119888-91201	PANEL ASSY, INSTRUM	Y00R4520	19	11	1C06	
119660-61071	GASKET, (NON-ASB.)	Y00R4520	13	3	1815	119888-91610	LABEL, CW & OIL LAMP	Y00R4520	19	24	1C06	
119660-61121	LINK L=88.8(INO COLOR	Y00R4520	13	11	1815	119888-91620	LABEL, KEY SWITCH	Y00R4520	19	25	1C06	
119660-61140	LINK L=88.6(WHITE)	Y00R4520	13	12	1815	121000-13201	GASKET, SILENCER	Y00R4520	6	4	1808	
119660-61150	LINK L=89.0(RED)	Y00R4520	13	13	1815					10	1808	
119660-61300	NUT, GOVERNOR WEIGHT	Y00R4520	13	9	1815				20	15	1C07	
119660-61341	SLEEVE, GOVERNOR	Y00R4520	13	10	1815	121023-01550	COVER, BLIND	Y00R4520	2	32	1803	
119660-61460	SHIM SET	Y00R4520	13	20	1815	121023-49150	HOSE, WATER DRAIN 165	Y00R4520	11	40	1813	
119660-61491	SHAFT, GOVERNOR LEVER	Y00R4520	13	28	1815	121111-21501	BOLT, FLYWHEEL	Y00R4520	8	11	1810	
119660-61651	SPRING, STARTING	Y00R4520	13	49	1815	121120-01620	BOLT M TOX 28	Y00R4520	3	6	1804	
119660-61901	RETAINER, SHAFT	Y00R4520	13	55	1815	121236-59080	PIPE, FUEL (D12XL400)	Y00R4520	15	21	1C02	
119688-21590	FLYWHEEL CMP	Y00R4520	8	12	1810	121250-44901	SWITCH, THERMO(110°C	Y00R4520	10	25	1812	
119688-44940	RETAINING BAR	Y00R4520	11	8	1813	121250-55620	SPRING	Y00R4520	15	11	1C02	
119688-44950	BRACKET (A)	Y00R4520	11	9	1813	121254-55510	CUP, STRAINER	Y00R4520	15	8	1C02	
119688-44961	BRACKET (B), RADIATOR	Y00R4520	11	10	1813	121256-44600	BRACKET, SUB-TANK	Y00R4520	11	29	1813	
119688-44971	BRACKET (L)	Y00R4520	11	11	1813	121400-44650	ABSORBER, SHOCK	Y00R4520	11	7	1813	
119688-44981	BRACKET (R)	Y00R4520	11	12	1813	121400-91520	ABSORBER	Y00R4520	19	22	1C06	
119688-49010	PIPE (A), C. WATER	Y00R4520	11	30	1813	121400-91530	SPACER	Y00R4520	19	23	1C06	
119688-66120	LINK, ENGINE CONTROL	Y00R4520	16	1	1C03	121450-01560	STUD M 8X 22	Y00R4520	2	18	1803	
119808-12540	VALVE, UNLOADER	Y00R4520	5	9	1807	121450-42450	PLUG M16	Y00R4520	10	27	1812	
119836-77200	GENERATOR	Y00R4520	18	1	1C05	121465-59950	BOLT M 6X 16, PLATED	Y00R4520	13	118	1816	
119836-77700	ROTOR ASSY	Y00R4520	18	2	1C05	121520-01851	GASKET, (NON-ASB.)	Y00R4520	15	1	1C02	
119836-77710	STARTER ASSY	Y00R4520	18	4	1C05	121520-34810	GUIDE, DIPSTICK	Y00R4520	9	13	1811	
119836-77721	COVER ASSY, REAR	Y00R4520	18	5	1C05	121550-49111	JOINT PT1/4	Y00R4520	11	43	1813	
119836-77730	COVER, REAR	Y00R4520	18	6	1C05	121575-66830	SCREW, ADJUST	Y00R4520	13	107	1815	
119836-77741	BRUSH ASSY, REGULATOR	Y00R4520	18	7	1C05	121750-49150	PIPE, C. WATER	Y00R4520	11	39	1813	
119836-77750	BRUSH ASSY	Y00R4520	18	8	1C05	121750-59890	RETAINER	Y00R4520	19	35	1C06	
119836-77760	GUIDE, FAN SIDE	Y00R4520	18	9	1C05					37	1C06	
119836-77770	DIODE ASSY	Y00R4520	18	10	1C05					38	1C06	
119836-77780	CONDENSER	Y00R4520	18	11	1C05					39	1C06	
119836-77790	COVER ASSY, FRONT	Y00R4520	18	15	1C05	121850-11860	PLUG PT1/4	Y00R4520	4	15	1805	
119836-77800	RETAINER, BEARING	Y00R4520	18	16	1C05	121855-13821	SPACER(A)	Y00R4520	6	17	1808	
119836-77810	PULLEY	Y00R4520	18	19	1C05	121855-13830	SPACER(B)	Y00R4520	6	18	1808	
119836-77820	NUT ASSY, PULLEY	Y00R4520	18	20	1C05	123500-13840	SPACER(C)	Y00R4520	6	19	1808	
119836-77830	BOLT, THROUGH	Y00R4520	18	21	1C05	124060-21600	GEAR, RING	Y00R4520	8	23	1810	
119836-77840	BALL BEARING	Y00R4520	18	17	1C05	124060-59380	PLUG	Y00R4520	15	28	1C02	
119836-77850	BALL BEARING	Y00R4520	18	3	1C05	124066-59100	CLAMP 8	Y00R4520	14	36	1C01	
119836-77860	SCREW KID	Y00R4520	18	18	1C05	124085-02220	SEAL, OIL	Y00R4520	3	12	1804	
119836-77871	BOLT (1)	Y00R4520	18	12	1C05	124160-01751	CAP, LUB.OIL SUPPLY	Y00R4520	2	12	1803	
119836-77880	BOLT (2)	Y00R4520	18	13	1C05					4	57	1805
119836-77890	WIRE ASSY, LEAD	Y00R4520	18	14	1C05	124160-11340	SEAL, VALVE STEM	Y00R4520	4	25	1805	
119840-13150	PIPE, EXHAUST	Y00R4520	6	3	1808				20	8	1C07	
119865-12600	STAY	Y00R4520	5	12	1807	124160-11360	KNOB	Y00R4520	4	61	1805	
119865-21600	GEAR, RING	Y00R4520	8	15	1810	124160-39450	SWITCH, OIL PRESSURE	Y00R4520	9	34	1811	
				19	1810	124160-59080	PIPE	Y00R4520	15	23	1C02	
119888-08110	BRACKET (B), ENGINE	Y00R4520	11	2	1813	124190-77110	ARMATURE, (NON-ASB.)	Y00R4520	17	19	1C04	
119888-21450	RETAINER, BEARING	Y00R4520	8	52	1810	124190-77760	PINION ASSY	Y00R4520	17	20	1C04	
119888-66110	BRACKET	Y00R4520	16	4	1C03	124250-49351	THERMOMETER	Y00R4520	10	29	1812	
119888-66130	PIVOT	Y00R4520	16	5	1C03	124450-44510	TANK	Y00R4520	11	23	1813	
119888-91021	HARNESS (A), WIRE	Y00R4520	19	2	1C06	124450-44530	CAP	Y00R4520	11	25	1813	
119888-91031	HARNESS (B), WIRE	Y00R4520	19	18	1C06	124450-44550	CLAMP, SUB-TANK	Y00R4520	11	28	1813	

PART NO.	DESCRIPTION	CATALOG NO.	GRP. NO.	REF. NO.	LOC. NO.	I	PART NO.	DESCRIPTION	CATALOG NO.	GRP. NO.	REF. NO.	LOC. NO.	
124450-44560	CLAMP	YOOR4520	11	26	1B13	I	171102-66080	SPACER	YOOR4520	16	7	1C03	
124465-44950	GASKET 16	YOOR4520	10	26	1B12	I	171301-01640	PLUG M22	YOOR4520	3	21	1B04	
				28	1B12	I	171375-39600	DAMPER ASSY	YOOR4520	9	35	1B11	
				20	19	1C07	I	174307-51700	SHIM SET	YOOR4520	13	31	1B15
124550-55700	ELEMENT, FUEL	YOOR4520	15	13	1C02	I	194180-51640	CLAMP, WIRE HARNESS	YOOR4520	19	36	1C06	
124550-66370	LOCK NUT M 6	YOOR4520	13	66	1B15	I	194990-22050	NUT W/WASHER B	YOOR4520	2	30	1B03	
124550-77030	COVER, TERMINAL	YOOR4520	19	1	1C06	I				6	5	1B08	
124559-77971	LAMP, PILOT	YOOR4520	19	16	1C06	I					26	1B08	
124664-13580	CLAMP	YOOR4520	6	15	1B08	I					28	1B08	
124700-44740	FAN, COOLING	YOOR4520	10	19	1B12	I					13	1	1B15
124701-91140	CABLE L= 985	YOOR4520	19	4	1C06	I	22111-060000	WASHER 6	YOOR4520	13	120	1B16	
124732-77720	LAMP, CHARGING	YOOR4520	19	13	1C06	I	22117-040000	WASHER 4	YOOR4520	13	51	1B15	
124766-59050	CLAMP 12	YOOR4520	11	41	1B13	I	22117-050000	WASHER 5	YOOR4520	19	26	1C06	
				15	20	1C02	I					27	1C06
124770-91220	COVER S2	YOOR4520	19	21	1C06	I	22117-100000	WASHER 10	YOOR4520	16	22	1C03	
124950-11340	SEAL, VALVE STEM	YOOR4520	4	26	1B05	I	22137-040000	WASHER 4, POLISHED	YOOR4520	12	43	1B14	
				20	7	1C07	I	22137-080000	WASHER 8, POLISHED	YOOR4520	11	13	1B13
126650-66020	HANDLE, REGULATOR	YOOR4520	16	3	1C03	I	22190-060002	SEAL WASHER 6S	YOOR4520	15	29	1C02	
128300-77920	TIMER	YOOR4520	19	15	1C06	I	22190-060003	SEAL WASHER 6	YOOR4520	13	115	1B15	
129100-01580	PARALLEL PIN 8X16	YOOR4520	3	1	1B04	I	22190-080002	SEAL WASHER 8S	YOOR4520	15	30	1C02	
				8	2	1B10	I				31	1C02	
129100-61930	NUT, CAP	YOOR4520	13	63	1B15	I					20	22	1C07
129122-44480	JOINT	YOOR4520	9	42	1B11	I	22190-120002	SEAL WASHER 12S	YOOR4520	13	116	1B16	
129150-35350	NUT	YOOR4520	9	27	1B11	I	22190-220002	SEAL WASHER 22S	YOOR4520	3	19	1B04	
129150-49080	COCK, DRAIN	YOOR4520	11	35	1B13	I	22217-040000	SPRING WASHER 4	YOOR4520	12	44	1B14	
129150-49100	COCK ASSY, 3-WAY	YOOR4520	11	34	1B13	I	22217-050000	SPRING WASHER 5	YOOR4520	4	59	1B05	
129150-49360	GASKET 10	YOOR4520	10	30	1B12	I	22217-100000	SPRING WASHER 10	YOOR4520	11	14	1B13	
129150-59120	RETAINER, INJ. PIPE	YOOR4520	14	18	1C01	I					16	23	1C03
129150-59131	BOLT M4X14, HEX. SCKT.	YOOR4520	14	21	1C01	I	22242-000120	CIRCLIP 12	YOOR4520	4	45	1B05	
129150-91400	GEAR UNIT, TACHOMETER	YOOR4520	2	35	1B03	I	22242-000200	CIRCLIP 20	YOOR4520	7	15	1B09	
129155-51280	O-RING S6	YOOR4520	13	16	1B15	I	22252-000210	CIRCLIP 21	YOOR4520	8	33	1B10	
129155-51580	O-RING	YOOR4520	14	2	1C01	I	22272-000040	CIRCLIP E- 4	YOOR4520	13	52	1B15	
				20	24	1C07	I	22272-000050	CIRCLIP E- 5	YOOR4520	16	24	1C03
129155-61480	SPACER ASSY	YOOR4520	13	23	1B15	I	22351-020006	SPRING PIN 2X 6	YOOR4520	16	17	1C03	
129350-49530	COVER, THERMOSTAT	YOOR4520	10	21	1B12	I	22351-030014	SPRING PIN 3X14	YOOR4520	13	53	1B15	
129350-49541	GASKET, (NON-ASB.)	YOOR4520	10	22	1B12	I	22351-040010	SPRING PIN 4X10	YOOR4520	2	19	1B03	
				20	18	1C07	I				13	60	1B15
129350-49800	THERMOSTAT (71°C	YOOR4520	10	23	1B12	I	22351-060012	SPRING PIN 6X12	YOOR4520	4	28	1B05	
129400-92410	FLEX HORN	YOOR4520	20	31	1C07	I					69	1B05	
129403-49050	PIPE, COOLER-C.W.PUMP	YOOR4520	9	44	1B11	I	22360-040000	SNAP PIN 4	YOOR4520	13	109	1B15	
129470-39610	DAMPER	YOOR4520	9	36	1B11	I	22360-060000	SNAP PIN 6	YOOR4520	13	110	1B15	
129795-77800	PLUG, GLOW	YOOR4520	4	63	1B05	I	22411-200150	COTTER PIN 2.0X15	YOOR4520	16	18	1C03	
144626-91560	TACHO UNIT	YOOR4520	9	38	1B11	I	22512-040120	KEY 4X 12	YOOR4520	7	8	1B09	
170064-67210	LABEL, HANDLE	YOOR4520	16	21	1C03	I					22	1B09	
171010-77850	THERMOMETER, C.W.	YOOR4520	19	14	1C06	I					8	6	1B10
171048-67010	REGULATOR ASSY	YOOR4520	16	6	1C03	I	23000-022000	CLAMP 22	YOOR4520	9	45	1B11	
171048-67130	LEVER	YOOR4520	16	15	1C03	I	23000-054000	CLAMP 54	YOOR4520	5	16	1B07	
171048-67140	STOPPER	YOOR4520	16	16	1C03	I	23010-038000	CLAMP 38	YOOR4520	11	33	1B13	
171059-55600	STRAINER ASSY, FUEL	YOOR4520	15	4	1C02	I	23061-070230	PIPE 7X 230	YOOR4520	11	27	1B13	
171080-91100	TACHOMETER	YOOR4520	19	19	1C06	I	23065-120500	PIPE, VINYL 12X 500	YOOR4520	4	1	1B05	
171085-67100	BRACKET, GEAR	YOOR4520	16	12	1C03	I	23161-020100	BUSH PT1/4X1/8	YOOR4520	9	37	1B11	
171085-67110	SHAFT, DRIVING	YOOR4520	16	13	1C03	I	23414-140000	GASKET 14, ROUND	YOOR4520	14	41	1C01	
171085-67120	GEAR	YOOR4520	16	14	1C03	I					20	21	1C07
171090-91010	GAUGE, PRESSURE	YOOR4520	19	17	1C06	I	23418-060000	GASKET 6, NYLON	YOOR4520	15	15	1C02	

PART NO.	DESCRIPTION	CATALOG NO.	GRP. NO.	REF. NO.	LOC. NO.	PART NO.	DESCRIPTION	CATALOG NO.	GRP. NO.	REF. NO.	LOC. NO.
23871-010000	PLUG PT1/8, SCREW	YOOR4520	1	11	1B02	26106-060802	BOLT M 6X 80 PLATED	YOOR4520	2	11	1B03
23871-030000	PLUG PT3/8, SCREW	YOOR4520	9	46	1B11	26106-060952	BOLT M 6X 95 PLATED	YOOR4520	13	71	1B15
			10	14	1B12	26106-080122	BOLT M 8X 12 PLATED	YOOR4520	11	15	1B13
24101-062034	BALL BEARING	YOOR4520	7	24	1B09				19	3	1C06
24102-063034	BALL BEARING 6303U	YOOR4520	7	23	1B09	26106-080142	BOLT M 8X 14 PLATED	YOOR4520	4	3	1B05
24107-062054	BALL BEARING	YOOR4520	8	53	1B10				4	4	1B05
24311-000120	O-RING 1A P 12.0	YOOR4520	2	6	1B03				5	18	1B07
			4	62	1B05	26106-080162	BOLT M 8X 16 PLATED	YOOR4520	11	16	1B13
			9	32	1B11				42	1813	
			20	25	1C07				16	27	1C03
				27	1C07	26106-080182	BOLT M 8X 18 PLATED	YOOR4520	18	26	1C05
24311-000160	O-RING 1A P-16.0	YOOR4520	9	28	1B11	26106-080202	BOLT M 8X 20 PLATED	YOOR4520	9	29	1B11
			20	26	1C07				10	24	1B12
24311-000320	O-RING 1A P-32.0	YOOR4520	2	13	1B03				11	17	1B13
			4	58	1B05	26106-080222	BOLT M 8X 22 PLATED	YOOR4520	8	54	1B10
			20	5	1C07	26106-080252	BOLT M 8X 25 PLATED	YOOR4520	11	18	1B13
				11	1C07	26106-080402	BOLT M 8X 40 PLATED	YOOR4520	6	6	1B08
24311-240100	O-RING 1A P-10A	YOOR4520	15	17	1C02	26106-080452	BOLT M 8X 45 PLATED	YOOR4520	4	48	1B05
24321-000600	O-RING 1A G-60.0	YOOR4520	9	47	1B11				10	16	1B12
			20	28	1C07	26106-080552	BOLT M 8X 55 PLATED	YOOR4520	6	20	1B08
24321-000700	O-RING 1A G-70.0	YOOR4520	9	48	1B11	26106-081052	BOLT M 8X105 PLATED	YOOR4520	18	22	1C05
			20	29	1C07	26106-100202	BOLT M10X 20 PLATED	YOOR4520	11	3	1B13
24341-000070	O-RING 1A S-7.0	YOOR4520	13	61	1B15	26106-100502	BOLT M10X 50 PLATED	YOOR4520	19	9	1C06
24341-000240	O-RING 1A S-24.0	YOOR4520	2	33	1B03	26116-050102	BOLT M 5X 10 PLATED	YOOR4520	13	112	1B15
				37	1B03				19	28	1C06
			20	25	1C07	26116-060082	BOLT M 6X 8 PLATED	YOOR4520	16	19	1C03
24341-000250	O-RING 1A S-25.0	YOOR4520	3	24	1B04	26116-060304	BOLT M 6X 30 PLATED	YOOR4520	13	113	1B15
24341-000280	O-RING 1A S-28.0	YOOR4520	13	69	1B15	26116-100202	BOLT M10X 20 PLATED	YOOR4520	3	5	1B04
26014-060162	BOLT M 6X 16	YOOR4520	10	20	1B12	26116-100302	BOLT M10X 30 PLATED	YOOR4520	11	19	1B13
26014-080702	BOLT W/WASHER M8X 70	YOOR4520	15	18	1C02	26116-120252	BOLT M12X 25 PLATED	YOOR4520	17	21	1C04
26022-040082	SCREW M 4X 8	YOOR4520	12	45	1B14	26206-100252	BOLT M10X25	YOOR4520	3	8	1B04
26033-060202	SCREW M 6X 20	YOOR4520	19	8	1C06	26216-080222	STUD M 8X 22 PLATED	YOOR4520	6	7	1B08
26106-060102	BOLT M 6X 10 PLATED	YOOR4520	9	33	1B11				27	1B08	
			13	62	1B15	26216-080552	STUD M 8X 55 PLATED	YOOR4520	6	8	1B08
			16	25	1C03	26216-080702	STUD M 8X 70 PLATED	YOOR4520	6	9	1B08
26106-060122	BOLT M 6X 12 PLATED	YOOR4520	1	22	1B02	26347-040002	U-NUT M 4	YOOR4520	6	21	1B08
			3	25	1B04	26347-060002	U NUT 6	YOOR4520	6	22	1B08
			5	17	1B07	26366-060002	NUT M 6	YOOR4520	2	31	1B03
			7	16	1B09	26366-080002	NUT M 8	YOOR4520	4	49	1B05
26106-060162	BOLT M 6X 16 PLATED	YOOR4520	2	7	1B03				6	23	1B08
				38	1B03				11	20	1B13
			5	3	1B07				18	24	1C05
			7	25	1B09	26450-060202	BOLT M 6X 20	YOOR4520	9	12	1B11
			15	3	1C02	26557-040352	SCREW M 4X 35	YOOR4520	6	24	1B08
26106-060182	BOLT M 6X 18 PLATED	YOOR4520	2	34	1B03	26557-050102	SCREW M 5X 10	YOOR4520	4	60	1B05
26106-060222	BOLT M 6X 22 PLATED	YOOR4520	3	13	1B04	26587-040102	SCREW M 4X 10	YOOR4520	12	46	1B14
26106-060302	BOLT M 6X 30 PLATED	YOOR4520	2	8	1B03	26587-080102	SCREW M 8X 10	YOOR4520	7	26	1B09
26106-060402	BOLT M 6X 40 PLATED	YOOR4520	5	4	1B07	26657-100002	CAP NUT M10	YOOR4520	16	26	1C03
			6	25	1B08	26716-050002	NUT M 5	YOOR4520	19	29	1C06
26106-060452	BOLT M 6X 45 PLATED	YOOR4520	3	26	1B04	26716-100002	NUT M10	YOOR4520	11	21	1B13
26106-060602	BOLT M 6X 60 PLATED	YOOR4520	2	9	1B03	26756-050002	LOCK NUT M 5 PLATED	YOOR4520	16	2	1C03
				10	1B03	26756-060002	LOCK NUT M 6 PLATED	YOOR4520	4	40	1B05
26106-060702	BOLT M 6X 70 PLATED	YOOR4520	13	111	1B15				44	1B05	
26106-060752	BOLT M 6X 75 PLATED	YOOR4520	13	117	1B16				13	114	1B15